

LM111, LM211, LM311 DIFFERENTIAL COMPARATORS WITH STROBES

SLCS007H – SEPTEMBER 1973 – REVISED AUGUST 2003

- **Fast Response Times**
- **Strobe Capability**
- **Maximum Input Bias Current . . . 300 nA**
- **Maximum Input Offset Current . . . 70 nA**
- **Can Operate From Single 5-V Supply**
- **Available in Q-Temp Automotive**
 - **High-Reliability Automotive Applications**
 - **Configuration Control/Print Support**
 - **Qualification to Automotive Standards**

LM111 . . . JG PACKAGE
LM211 . . . D, P, OR PW PACKAGE
LM311 . . . D, P, PS, OR PW PACKAGE
(TOP VIEW)

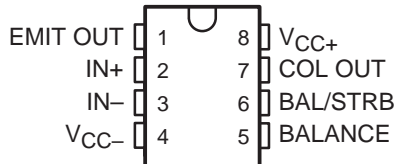

LM111 . . . FK PACKAGE
(TOP VIEW)

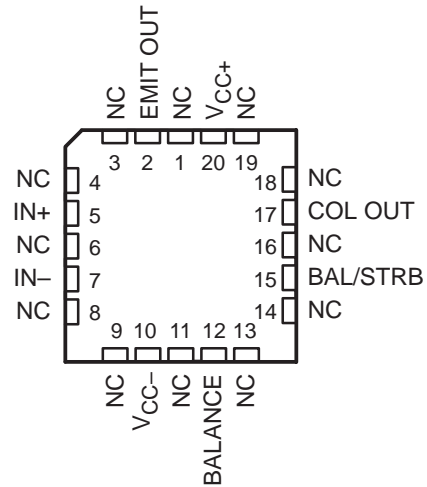

NC – No internal connection

description/ordering information

The LM111, LM211, and LM311 are single high-speed voltage comparators. These devices are designed to operate from a wide range of power-supply voltages, including ± 15 -V supplies for operational amplifiers and 5-V supplies for logic systems. The output levels are compatible with most TTL and MOS circuits. These comparators are capable of driving lamps or relays and switching voltages up to 50 V at 50 mA. All inputs and outputs can be isolated from system ground. The outputs can drive loads referenced to ground, V_{CC+} or V_{CC-} . Offset balancing and strobe capabilities are available, and the outputs can be wire-OR connected. If the strobe is low, the output is in the off state, regardless of the differential input.



Please be aware that an important notice concerning availability, standard warranty, and use in critical applications of Texas Instruments semiconductor products and disclaimers thereto appears at the end of this data sheet.

PRODUCTION DATA information is current as of publication date. Products conform to specifications per the terms of Texas Instruments standard warranty. Production processing does not necessarily include testing of all parameters.

 **TEXAS
INSTRUMENTS**

POST OFFICE BOX 655303 • DALLAS, TEXAS 75265

Copyright © 2003, Texas Instruments Incorporated
On products compliant to MIL-PRF-38535, all parameters are tested unless otherwise noted. On all other products, production processing does not necessarily include testing of all parameters.

LM111, LM211, LM311 DIFFERENTIAL COMPARATORS WITH STROBES

SLCS007H – SEPTEMBER 1973 – REVISED AUGUST 2003

description/ordering information

ORDERING INFORMATION

TA	V _{IO} max AT 25°C	PACKAGE†		ORDERABLE PART NUMBER	TOP-SIDE MARKING
-0°C to 70°C	7.5 mV	PDIP (P)	Tube of 50	LM311P	LM311P
		SOIC (D)	Tube of 75	LM311D	LM311
			Reel of 2500	LM311DR	
		SOP (PS)	Reel of 2000	LM311PSR	L311
		TSSOP (PW)	Reel of 150	LM311PW	L311
Tube of 2000	LM311PWR				
-40°C to 85°C	3 mV	PDIP (P)	Tube of 50	LM211P	LM211P
		SOIC (D)	Tube of 75	LM211D	LM211
			Reel of 2500	LM211DR	
		TSSOP (PW)	Reel of 150	LM211PW	L211
			Reel of 2000	LM211PWR	
-40°C to 125°C	3 mV	SOIC (D)	Tube of 75	LM211QD	LM211Q
			Reel of 2500	LM211QDR	
-55°C to 125°C	3 mV	CDIP (JG)	Tube of 50	LM111JG	LM111JG
		LCCC (FK)	Tube of 55	LM111FK	LM111FK

† Package drawings, standard packing quantities, thermal data, symbolization, and PCB design guidelines are available at www.ti.com/sc/package.

functional block diagram

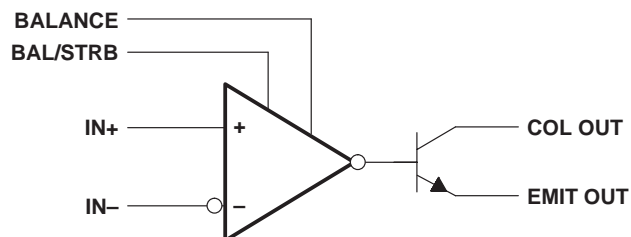

LM111, LM211, LM311 DIFFERENTIAL COMPARATORS WITH STROBES

SLCS007H – SEPTEMBER 1973 – REVISED AUGUST 2003

schematic

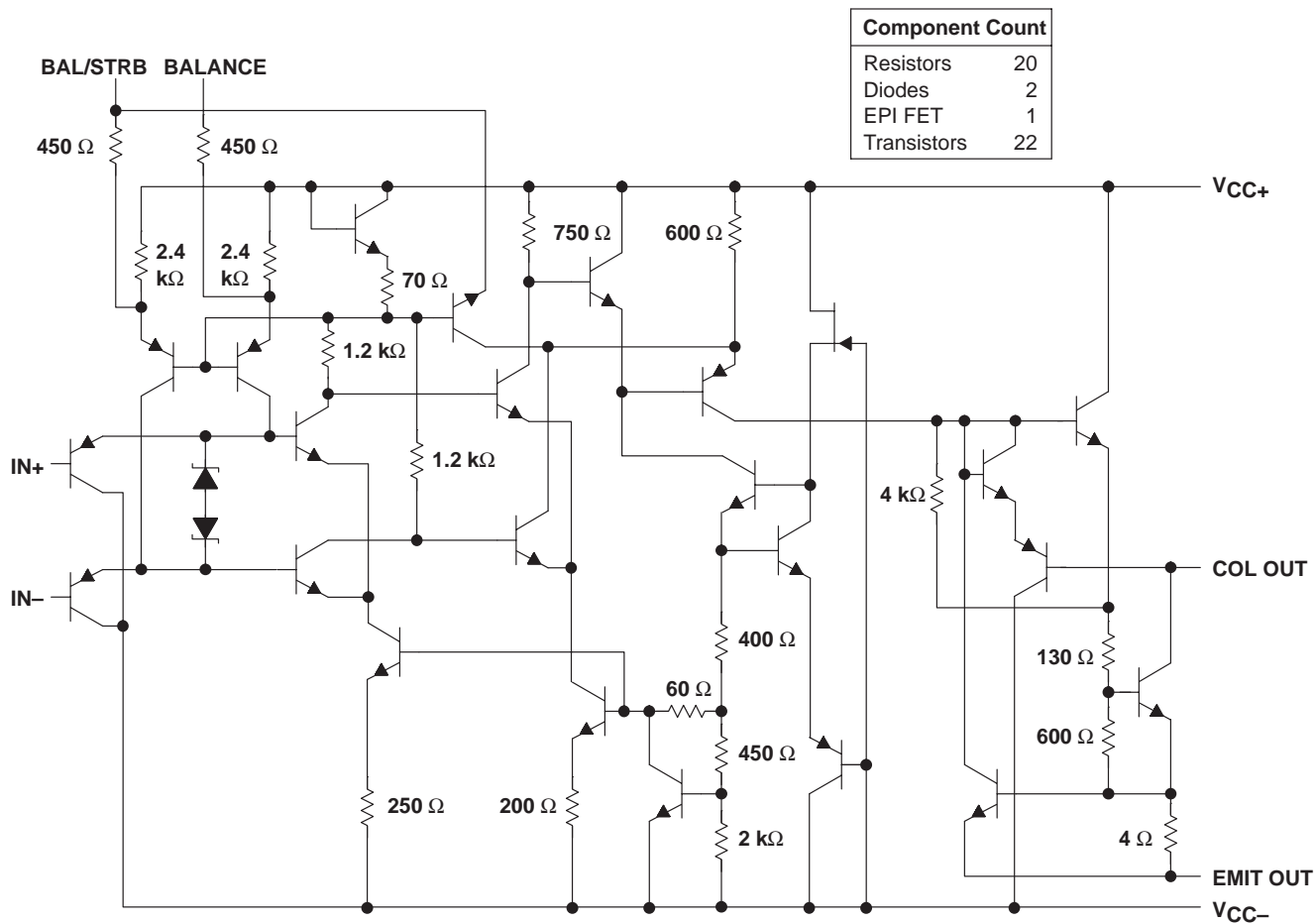

All resistor values shown are nominal.

LM111, LM211, LM311

DIFFERENTIAL COMPARATORS WITH STROBES

SLCS007H – SEPTEMBER 1973 – REVISED AUGUST 2003

absolute maximum ratings over operating free-air temperature range (unless otherwise noted)†

Supply voltage: V_{CC+} (see Note 1)	18 V
V_{CC-} (see Note 1)	-18 V
$V_{CC+} - V_{CC-}$	36 V
Differential input voltage, V_{ID} (see Note 2)	± 30 V
Input voltage, V_I (either input, see Notes 1 and 3)	± 15 V
Voltage from emitter output to V_{CC-}	30 V
Voltage from collector output to V_{CC-} : LM111	50 V
LM211	50 V
LM211Q	50 V
LM311	40 V
Duration of output short circuit (see Note 4)	10 s
Package thermal impedance, θ_{JA} (see Notes 5 and 6): D package	97°C/W
P package	85°C/W
PS package	95°C/W
PW package	149°C/W
Package thermal impedance, θ_{JC} (see Notes 7 and 8): FK package	5.61°C/W
JG package	14.5°C/W
Operating virtual junction temperature, T_J	150°C
Case temperature for 60 seconds: FK package	260°C
Lead temperature 1,6 mm (1/16 inch) from case for 10 seconds: J or JG package	300°C
Lead temperature 1,6 mm (1/16 inch) from case for 60 seconds: D, P, PS, or PW package	260°C
Storage temperature range, T_{Stg}	-65°C to 150°C

† Stresses beyond those listed under “absolute maximum ratings” may cause permanent damage to the device. These are stress ratings only, and functional operation of the device at these or any other conditions beyond those indicated under “recommended operating conditions” is not implied. Exposure to absolute-maximum-rated conditions for extended periods may affect device reliability.

- NOTES:
- All voltage values, unless otherwise noted, are with respect to the midpoint between V_{CC+} and V_{CC-} .
 - Differential voltages are at $IN+$ with respect to $IN-$.
 - The magnitude of the input voltage must never exceed the magnitude of the supply voltage or ± 15 V, whichever is less.
 - The output may be shorted to ground or either power supply.
 - Maximum power dissipation is a function of $T_J(max)$, θ_{JA} , and T_A . The maximum allowable power dissipation at any allowable ambient temperature is $P_D = (T_J(max) - T_A)/\theta_{JA}$. Operating at the absolute maximum T_J of 150°C can affect reliability.
 - The package thermal impedance is calculated in accordance with JESD 51-7.
 - Maximum power dissipation is a function of $T_J(max)$, θ_{JC} , and T_C . The maximum allowable power dissipation at any allowable case temperature is $P_D = (T_J(max) - T_C)/\theta_{JC}$. Operating at the absolute maximum T_J of 150°C can affect reliability.
 - The package thermal impedance is calculated in accordance with MIL-STD-883.

recommended operating conditions

		MIN	MAX	UNIT	
$V_{CC+} - V_{CC-}$	Supply voltage	3.5	30	V	
V_I	Input voltage ($ V_{CC\pm} \leq 15$ V)	$V_{CC-} + 0.5$	$V_{CC+} - 1.5$	V	
T_A	Operating free-air temperature range	LM111	-55	125	°C
		LM211	-40	85	
		LM211Q	-40	125	
		LM311	0	70	



LM111, LM211, LM311 DIFFERENTIAL COMPARATORS WITH STROBES

SLCS007H – SEPTEMBER 1973 – REVISED AUGUST 2003

electrical characteristics at specified free-air temperature, $V_{CC\pm} = \pm 15$ V (unless otherwise noted)

PARAMETER	TEST CONDITIONS	T_A †	LM111 LM211 LM211Q			LM311			UNIT
			MIN	TYP‡	MAX	MIN	TYP‡	MAX	
V_{IO} Input offset voltage	See Note 6	25°C	0.7		3	2		7.5	mV
		Full range			4			10	
I_{IO} Input offset current	See Note 6	25°C	4		10	6		50	nA
		Full range			20			70	
I_{IB} Input bias current	$V_O = 1$ V to 14 V	25°C	75		100	100		250	nA
		Full range			150			300	
$I_{IL(S)}$ Low-level strobe current (see Note 7)	$V(\text{strobe}) = 0.3$ V, $V_{ID} \leq -10$ mV	25°C	-3			-3			mA
V_{ICR} Common-mode input voltage range		Full range	13 to -14.5	13.8 to -14.7		13 to -14.5	13.8 to -14.7		V
A_{VD} Large-signal differential voltage amplification	$V_O = 5$ V to 35 V, $R_L = 1$ k Ω	25°C	40		200	40		200	V/mV
I_{OH} High-level (collector) output leakage current	$I(\text{strobe}) = -3$ mA, $V_{OH} = 35$ V, $V_{ID} = 5$ mV	25°C	0.2		10				nA
		Full range			0.5				μ A
V_{OL} Low-level (collector-to-emitter) output voltage	$I_{OL} = 50$ mA	$V_{ID} = -5$ mV	25°C		0.75	1.5			V
		$V_{ID} = -10$ mV	25°C				0.75	1.5	
	$V_{CC+} = 4.5$ V, $V_{CC-} = 0$, $I_{OL} = 8$ mA	$V_{ID} = -6$ mV	Full range		0.23	0.4			
		$V_{ID} = -10$ mV	Full range				0.23	0.4	
I_{CC+} Supply current from V_{CC+} , output low	$V_{ID} = -10$ mV, No load	25°C	5.1		6	5.1		7.5	mA
I_{CC-} Supply current from V_{CC-} , output high	$V_{ID} = 10$ mV, No load	25°C	-4.1		-5	-4.1		-5	mA

† Unless otherwise noted, all characteristics are measured with BALANCE and BAL/STRB open and EMIT OUT grounded.

Full range for LM111 is -55°C to 125°C, for LM211 is -40°C to 85°C, for LM211Q is -40°C to 125°C, and for LM311 is 0°C to 70°C.

‡ All typical values are at $T_A = 25^\circ\text{C}$.

NOTES: 9. The offset voltages and offset currents given are the maximum values required to drive the collector output up to 14 V or down to 1 V with a pullup resistor of 7.5 k Ω to V_{CC+} . These parameters actually define an error band and take into account the worst-case effects of voltage gain and input impedance.

10. The strobe should not be shorted to ground; it should be current driven at -3 mA to -5 mA (see Figures 13 and 27).

switching characteristics, $V_{CC\pm} = \pm 15$ V, $T_A = 25^\circ\text{C}$

PARAMETER	TEST CONDITIONS	LM111 LM211 LM211Q LM311	UNIT
		TYP	
Response time, low-to-high-level output	$R_C = 500$ Ω to 5 V, $C_L = 5$ pF, See Note 8	115	ns
Response time, high-to-low-level output		165	ns

NOTE 11: The response time specified is for a 100-mV input step with 5-mV overdrive and is the interval between the input step function and the instant when the output crosses 1.4 V.



LM111, LM211, LM311 DIFFERENTIAL COMPARATORS WITH STROBES

SLCS007H – SEPTEMBER 1973 – REVISED AUGUST 2003

TYPICAL CHARACTERISTICS†

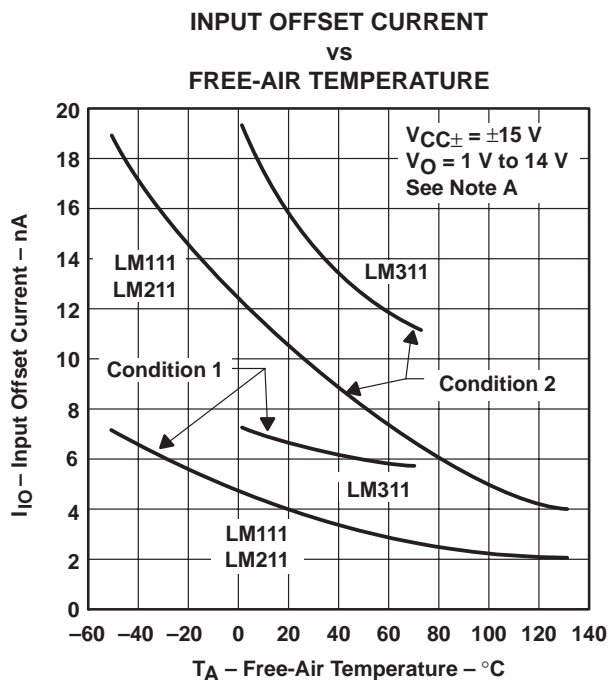

NOTE A: Condition 1 is with BALANCE and BAL/STRB open. Condition 2 is with BALANCE and BAL/STRB connected to V_{CC+} .

Figure 1

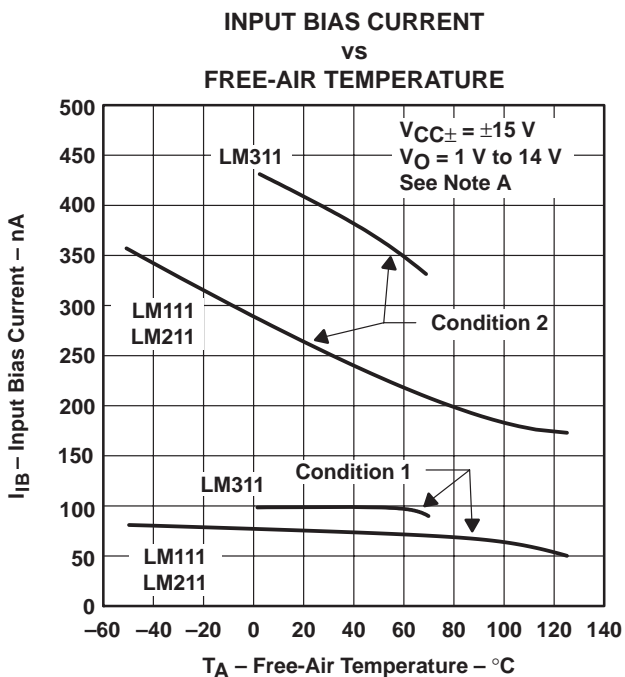

NOTE A: Condition 1 is with BALANCE and BAL/STRB open. Condition 2 is with BALANCE and BAL/STRB connected to V_{CC+} .

Figure 2

† Data at high and low temperatures are applicable only within the rated operating free-air temperature ranges of the various devices.



TYPICAL CHARACTERISTICS†

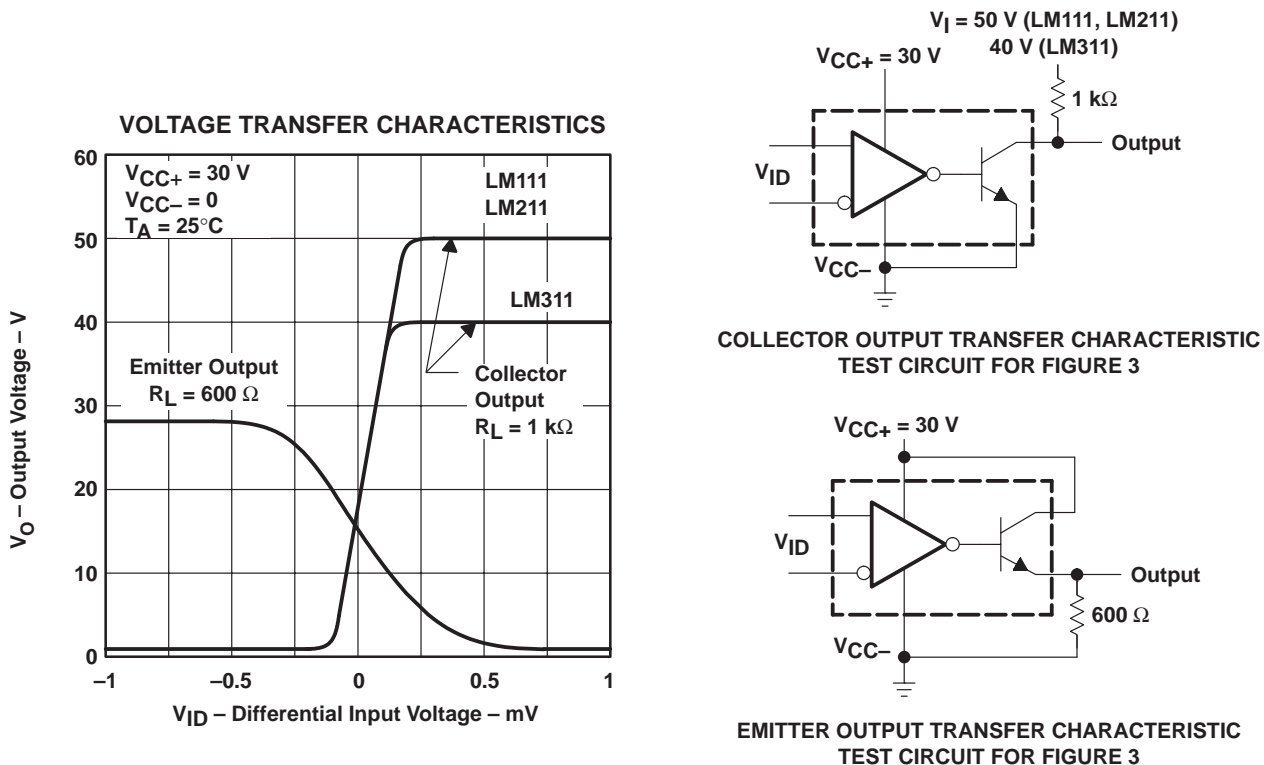

Figure 3

† Data at high and low temperatures are applicable only within the rated operating free-air temperature ranges of the various devices.

LM111, LM211, LM311 DIFFERENTIAL COMPARATORS WITH STROBES

SLCS007H – SEPTEMBER 1973 – REVISED AUGUST 2003

TYPICAL CHARACTERISTICS

OUTPUT RESPONSE FOR
VARIOUS INPUT OVERDRIVES

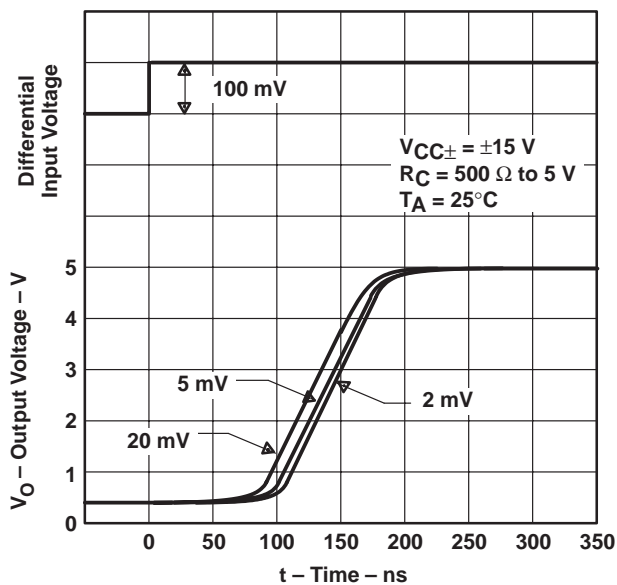

Figure 4

OUTPUT RESPONSE FOR
VARIOUS INPUT OVERDRIVES

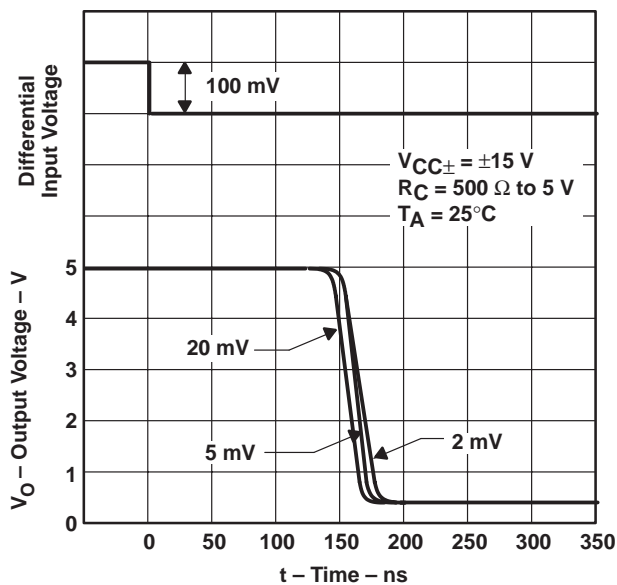
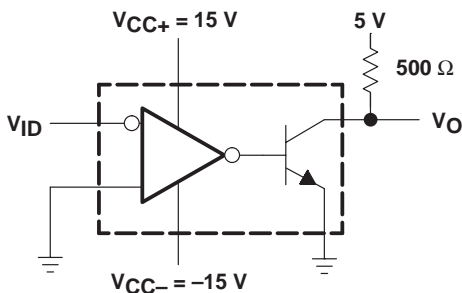

Figure 5



TEST CIRCUIT FOR FIGURES 4 AND 5

TYPICAL CHARACTERISTICS

OUTPUT RESPONSE FOR
VARIOUS INPUT OVERDRIVES

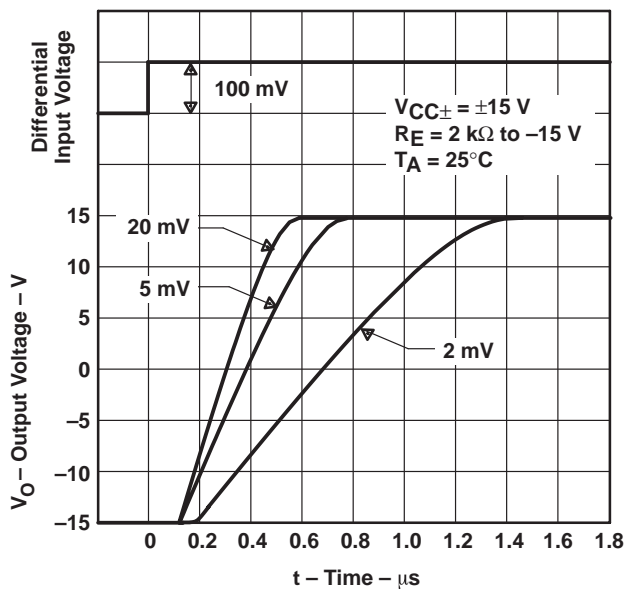

Figure 6

OUTPUT RESPONSE FOR
VARIOUS INPUT OVERDRIVES

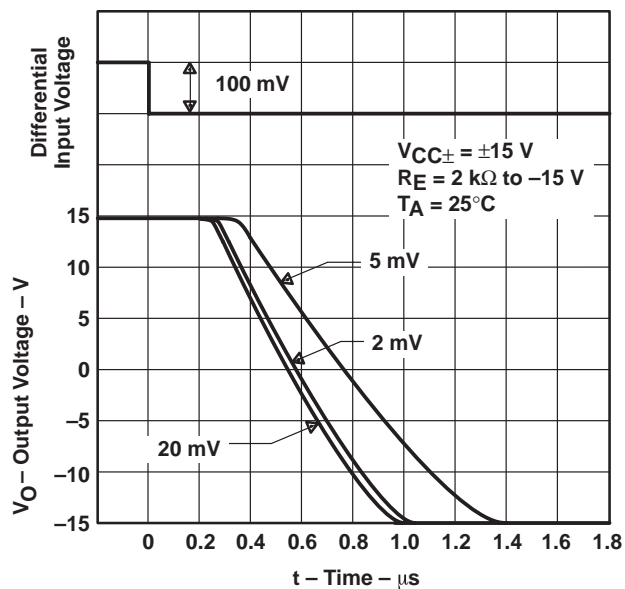
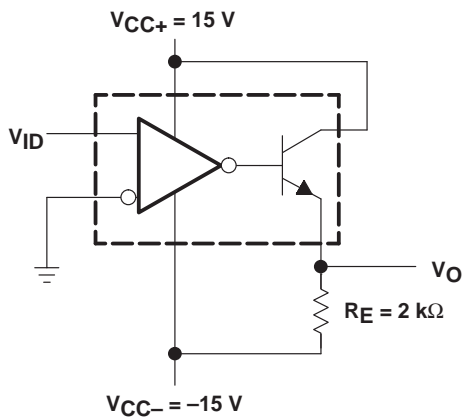

Figure 7



TEST CIRCUIT FOR FIGURES 6 AND 7

TYPICAL CHARACTERISTICS

OUTPUT CURRENT AND DISSIPATION
vs
OUTPUT VOLTAGE

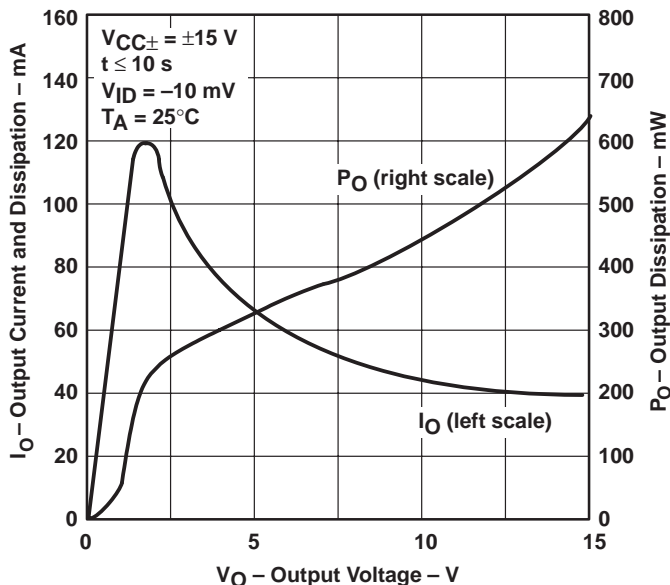

Figure 8

POSITIVE SUPPLY CURRENT
vs
POSITIVE SUPPLY VOLTAGE

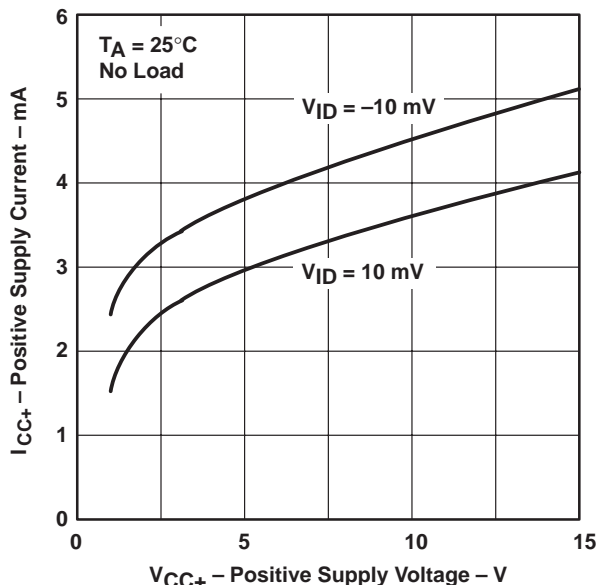

Figure 9

NEGATIVE SUPPLY CURRENT
vs
NEGATIVE SUPPLY VOLTAGE

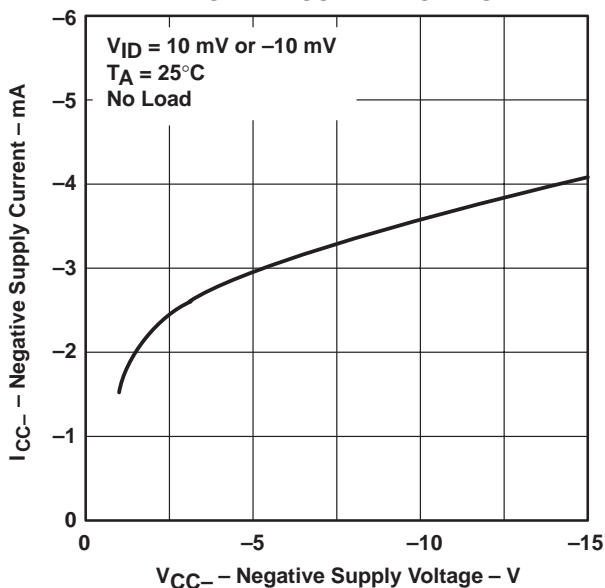

Figure 10



APPLICATION INFORMATION

Figure 11 through Figure 29 show various applications for the LM111, LM211, and LM311 comparators.

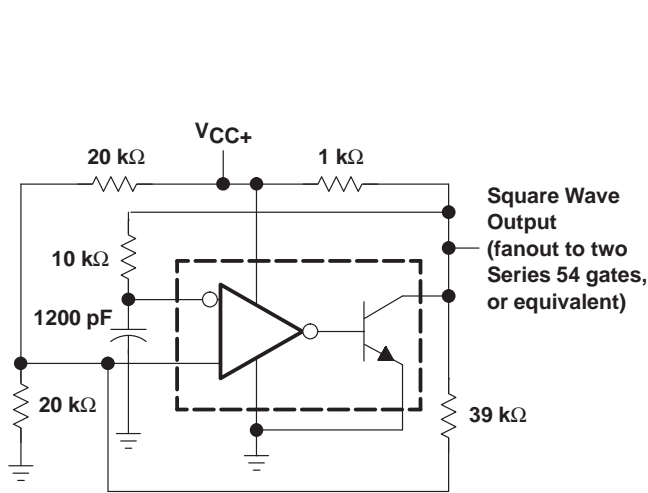
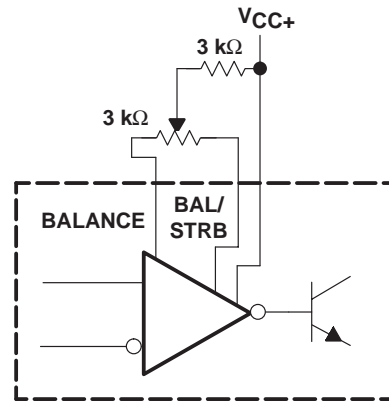

Figure 11. 100-kHz Free-Running Multivibrator



NOTE: If offset balancing is not used, the BALANCE and BAL/STRB pins should be shorted together.

Figure 12. Offset Balancing

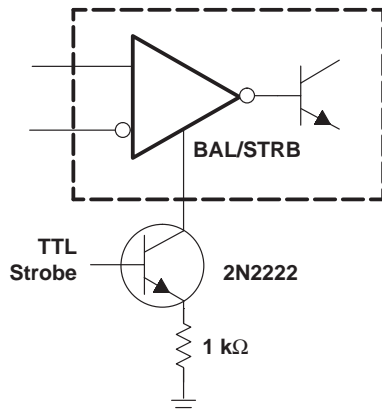

Figure 13. Strobbing

NOTE: Do not connect strobe pin directly to ground, because the output is turned off whenever current is pulled from the strobe pin.

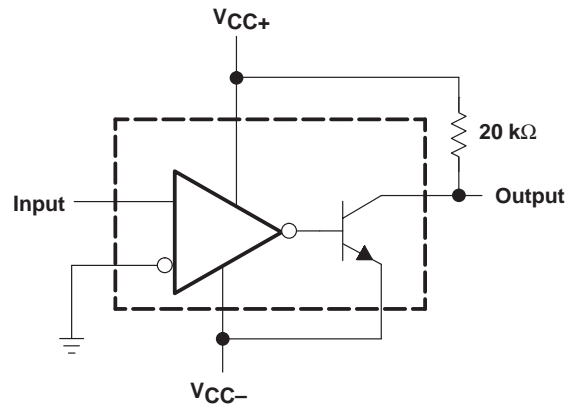
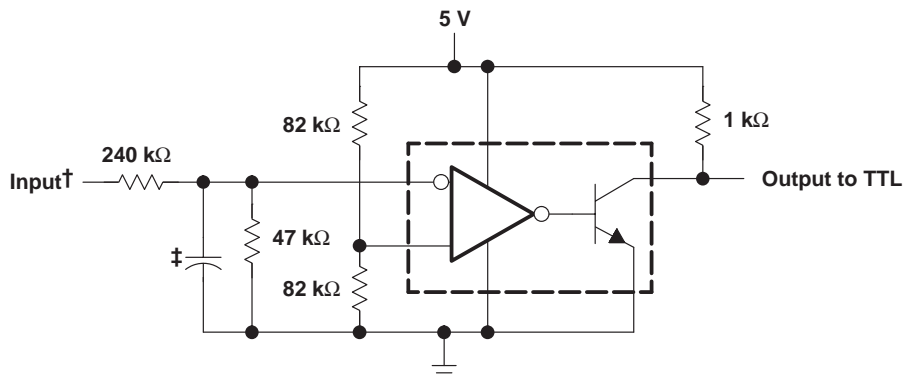

Figure 14. Zero-Crossing Detector

LM111, LM211, LM311 DIFFERENTIAL COMPARATORS WITH STROBES

SLCS007H – SEPTEMBER 1973 – REVISED AUGUST 2003

APPLICATION INFORMATION



† Resistor values shown are for a 0- to 30-V logic swing and a 15-V threshold.
‡ May be added to control speed and reduce susceptibility to noise spikes

Figure 15. TTL Interface With High-Level Logic

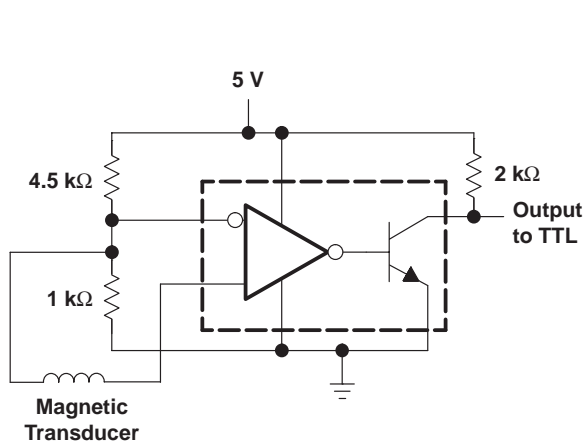

Figure 16. Detector for Magnetic Transducer

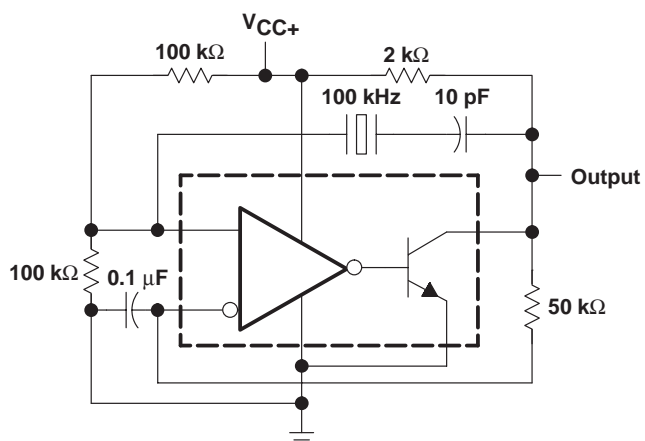

Figure 17. 100-kHz Crystal Oscillator

APPLICATION INFORMATION

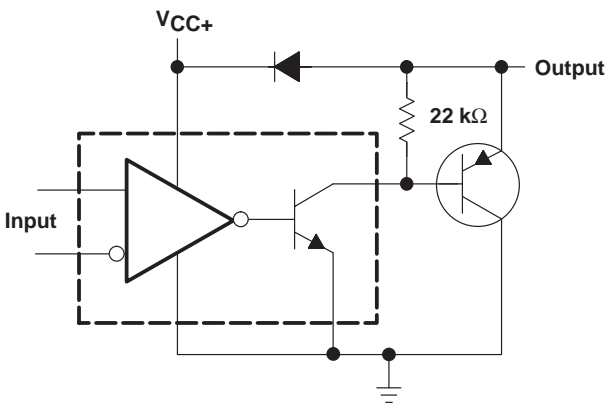
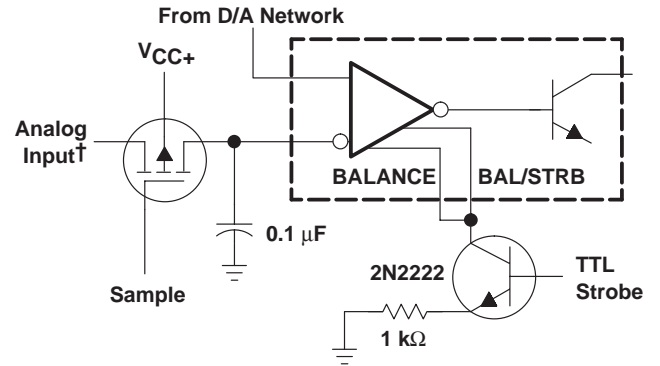

Figure 18. Comparator and Solenoid Driver



† Typical input current is 50 pA with inputs strobed off.

Figure 19. Strobing Both Input and Output Stages Simultaneously

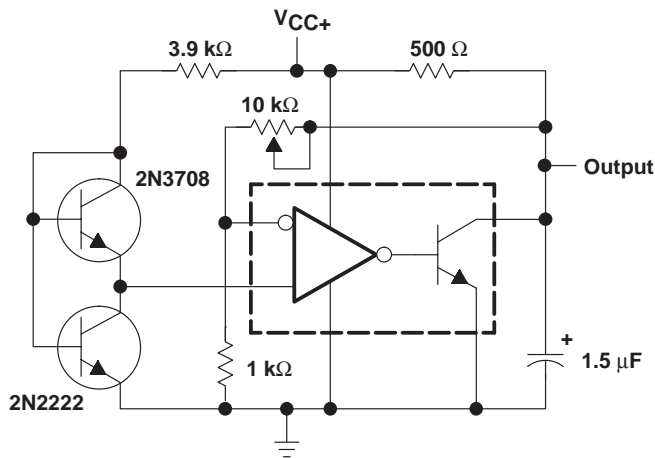

Figure 20. Low-Voltage Adjustable Reference Supply

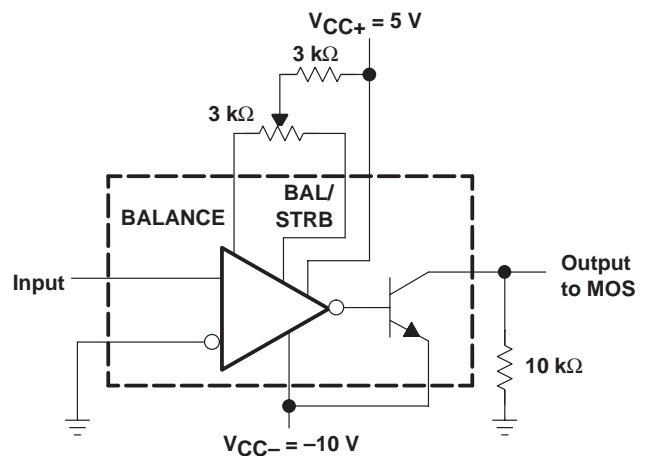
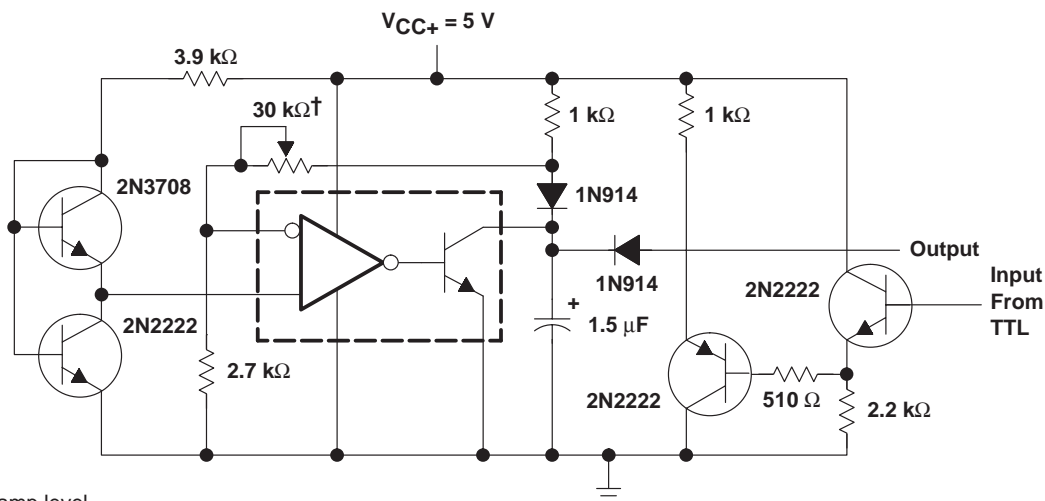

Figure 21. Zero-Crossing Detector Driving MOS Logic

APPLICATION INFORMATION



† Adjust to set clamp level

Figure 22. Precision Squarer

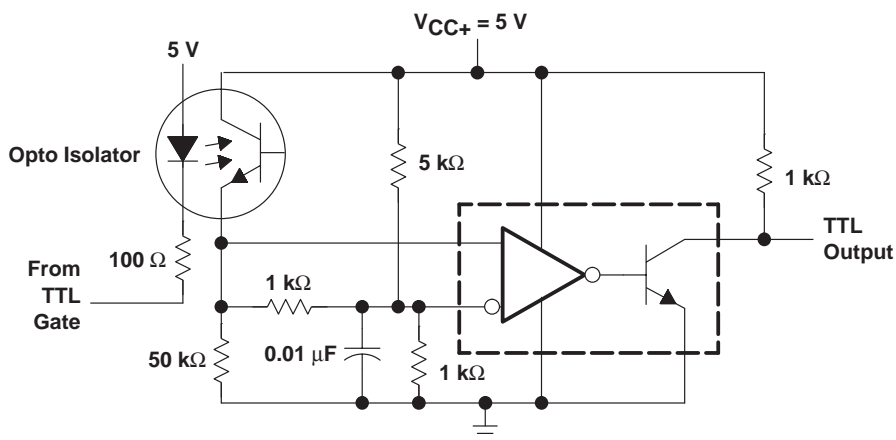

Figure 23. Digital Transmission Isolator

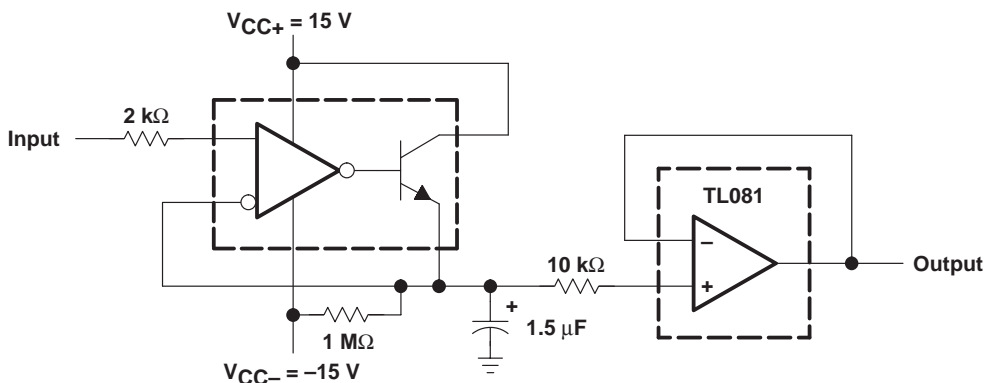

Figure 24. Positive-Peak Detector

APPLICATION INFORMATION

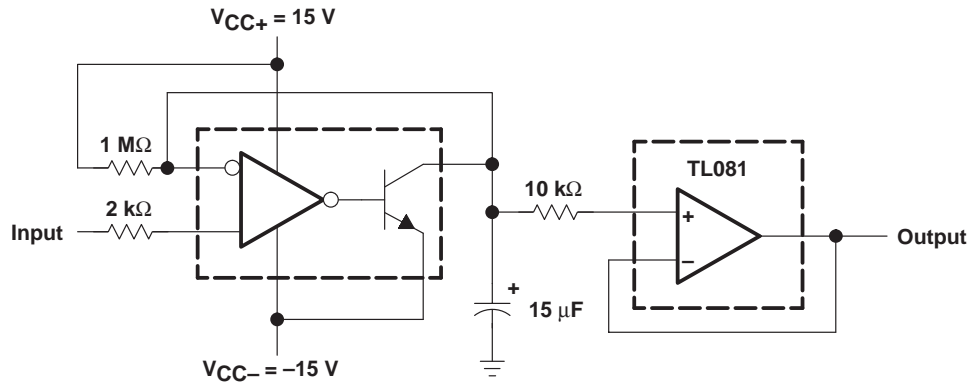
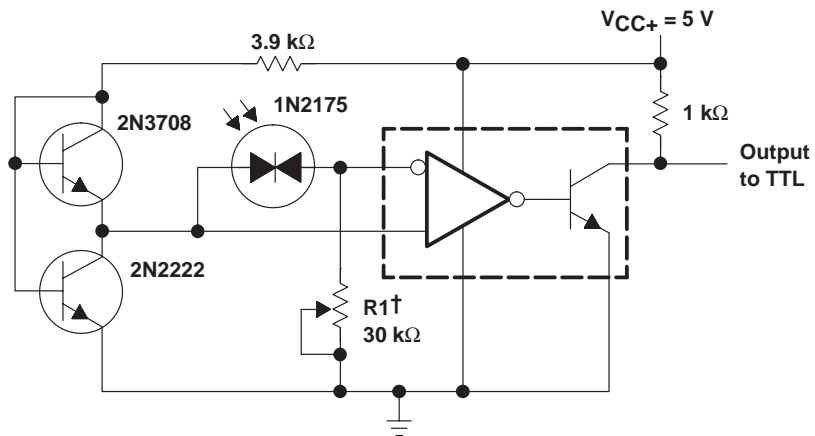
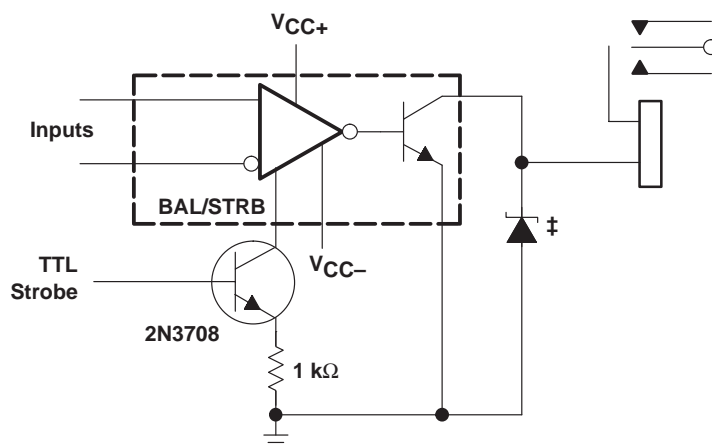

Figure 25. Negative-Peak Detector



† R1 sets the comparison level. At comparison, the photodiode has less than 5 mV across it, decreasing dark current by an order of magnitude.

Figure 26. Precision Photodiode Comparator



‡ Transient voltage and inductive kickback protection

Figure 27. Relay Driver With Strobe

LM111, LM211, LM311 DIFFERENTIAL COMPARATORS WITH STROBES

SLCS007H – SEPTEMBER 1973 – REVISED AUGUST 2003

APPLICATION INFORMATION

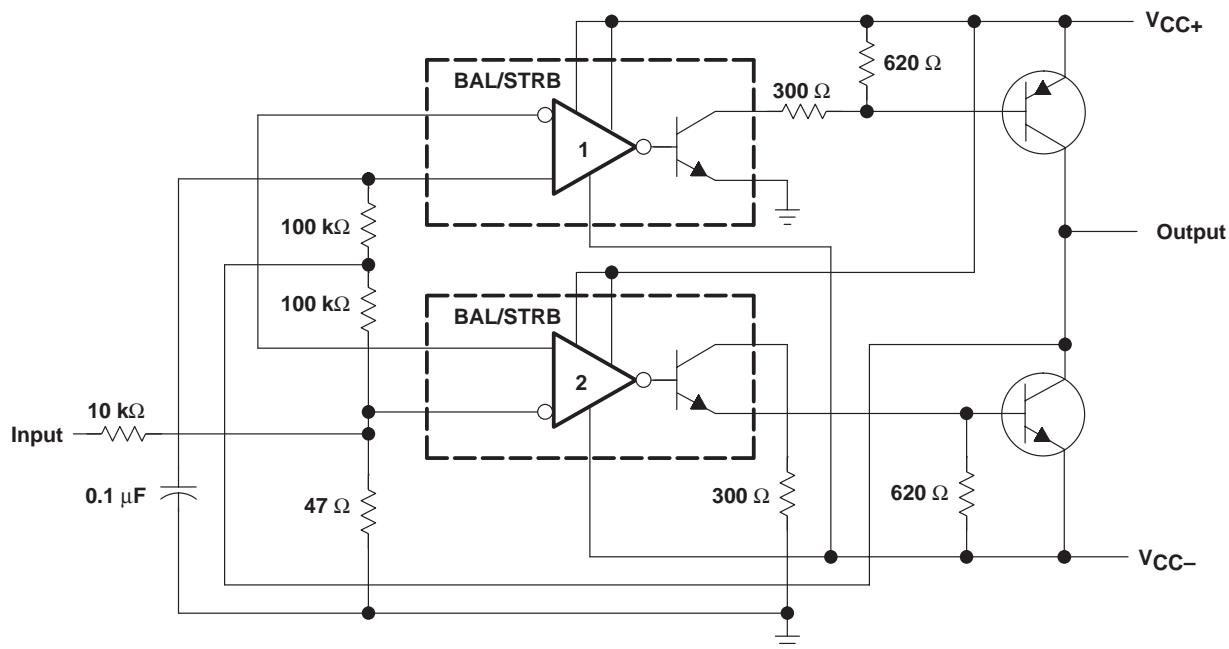

Figure 28. Switching Power Amplifier

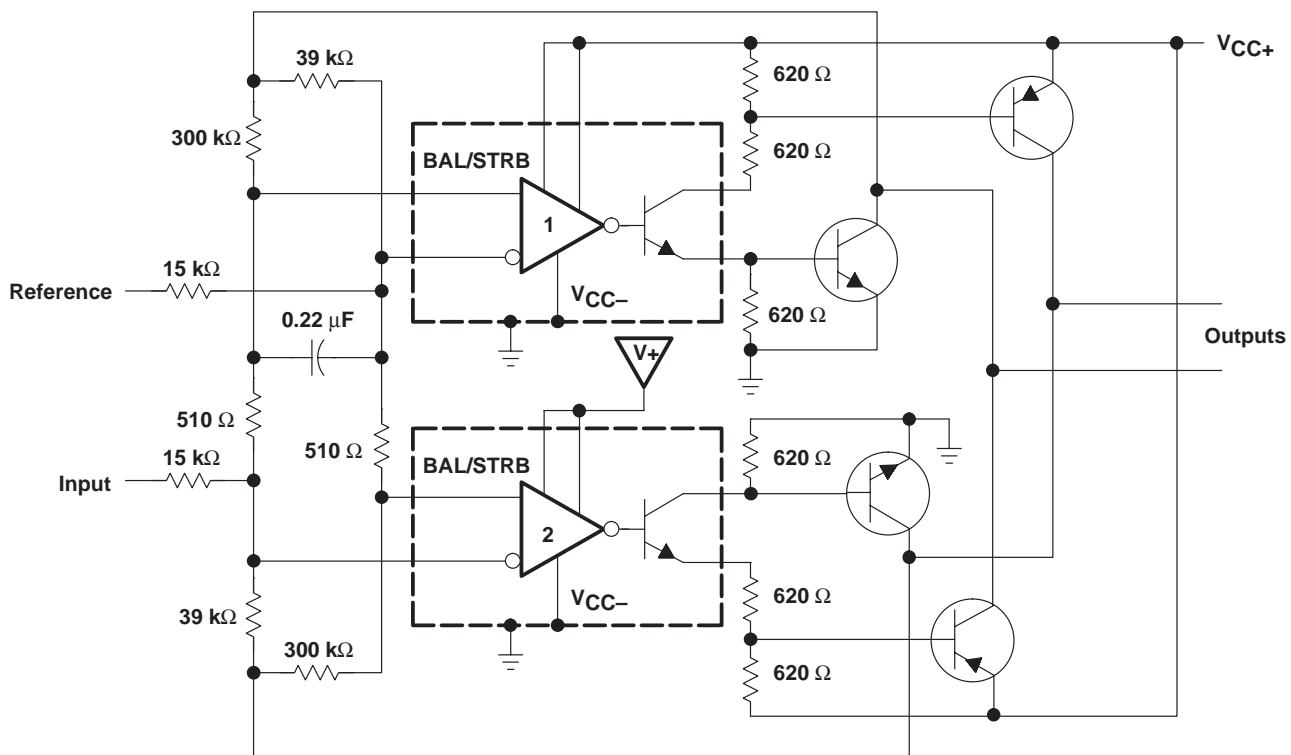

Figure 29. Switching Power Amplifiers

PACKAGING INFORMATION

Orderable Device	Status ⁽¹⁾	Package Type	Package Drawing	Pins	Package Qty	Eco Plan ⁽²⁾	Lead/Ball Finish	MSL Peak Temp ⁽³⁾
JM38510/10304BPA	ACTIVE	CDIP	JG	8	1	TBD	A42 SNPB	N / A for Pkg Type
LM111FKB	ACTIVE	LCCC	FK	20	1	TBD	POST-PLATE	N / A for Pkg Type
LM111JG	ACTIVE	CDIP	JG	8	1	TBD	A42 SNPB	N / A for Pkg Type
LM111JGB	ACTIVE	CDIP	JG	8	1	TBD	A42 SNPB	N / A for Pkg Type
LM211D	ACTIVE	SOIC	D	8	75	Green (RoHS & no Sb/Br)	CU NIPDAU	Level-1-260C-UNLIM
LM211DE4	ACTIVE	SOIC	D	8	75	Green (RoHS & no Sb/Br)	CU NIPDAU	Level-1-260C-UNLIM
LM211DG4	ACTIVE	SOIC	D	8	75	Green (RoHS & no Sb/Br)	CU NIPDAU	Level-1-260C-UNLIM
LM211DR	ACTIVE	SOIC	D	8	2500	Green (RoHS & no Sb/Br)	CU NIPDAU	Level-1-260C-UNLIM
LM211DRE4	ACTIVE	SOIC	D	8	2500	Green (RoHS & no Sb/Br)	CU NIPDAU	Level-1-260C-UNLIM
LM211DRG4	ACTIVE	SOIC	D	8	2500	Green (RoHS & no Sb/Br)	CU NIPDAU	Level-1-260C-UNLIM
LM211P	ACTIVE	PDIP	P	8	50	Pb-Free (RoHS)	CU NIPDAU	N / A for Pkg Type
LM211PE4	ACTIVE	PDIP	P	8	50	Pb-Free (RoHS)	CU NIPDAU	N / A for Pkg Type
LM211PW	ACTIVE	TSSOP	PW	8	150	Green (RoHS & no Sb/Br)	CU NIPDAU	Level-1-260C-UNLIM
LM211PWE4	ACTIVE	TSSOP	PW	8	150	Green (RoHS & no Sb/Br)	CU NIPDAU	Level-1-260C-UNLIM
LM211PWR	ACTIVE	TSSOP	PW	8	2000	Green (RoHS & no Sb/Br)	CU NIPDAU	Level-1-260C-UNLIM
LM211PWRE4	ACTIVE	TSSOP	PW	8	2000	Green (RoHS & no Sb/Br)	CU NIPDAU	Level-1-260C-UNLIM
LM211QD	ACTIVE	SOIC	D	8	75	Pb-Free (RoHS)	CU NIPDAU	Level-2-250C-1 YEAR/ Level-1-235C-UNLIM
LM211QDR	ACTIVE	SOIC	D	8	2500	Pb-Free (RoHS)	CU NIPDAU	Level-2-250C-1 YEAR/ Level-1-235C-UNLIM
LM311D	ACTIVE	SOIC	D	8	75	Green (RoHS & no Sb/Br)	CU NIPDAU	Level-1-260C-UNLIM
LM311DE4	ACTIVE	SOIC	D	8	75	Green (RoHS & no Sb/Br)	CU NIPDAU	Level-1-260C-UNLIM
LM311DG4	ACTIVE	SOIC	D	8	75	Green (RoHS & no Sb/Br)	CU NIPDAU	Level-1-260C-UNLIM
LM311DR	ACTIVE	SOIC	D	8	2500	Green (RoHS & no Sb/Br)	CU NIPDAU	Level-1-260C-UNLIM
LM311DRE4	ACTIVE	SOIC	D	8	2500	Green (RoHS & no Sb/Br)	CU NIPDAU	Level-1-260C-UNLIM
LM311DRG4	ACTIVE	SOIC	D	8	2500	Green (RoHS & no Sb/Br)	CU NIPDAU	Level-1-260C-UNLIM
LM311P	ACTIVE	PDIP	P	8	50	Pb-Free (RoHS)	CU NIPDAU	N / A for Pkg Type
LM311PE4	ACTIVE	PDIP	P	8	50	Pb-Free (RoHS)	CU NIPDAU	N / A for Pkg Type
LM311PSR	ACTIVE	SO	PS	8	2000	Green (RoHS & no Sb/Br)	CU NIPDAU	Level-1-260C-UNLIM

Orderable Device	Status ⁽¹⁾	Package Type	Package Drawing	Pins	Package Qty	Eco Plan ⁽²⁾	Lead/Ball Finish	MSL Peak Temp ⁽³⁾
						no Sb/Br)		
LM311PSRE4	ACTIVE	SO	PS	8	2000	Green (RoHS & no Sb/Br)	CU NIPDAU	Level-1-260C-UNLIM
LM311PW	ACTIVE	TSSOP	PW	8	150	Green (RoHS & no Sb/Br)	CU NIPDAU	Level-1-260C-UNLIM
LM311PWE4	ACTIVE	TSSOP	PW	8	150	Green (RoHS & no Sb/Br)	CU NIPDAU	Level-1-260C-UNLIM
LM311PWLE	OBSOLETE	TSSOP	PW	8		TBD	Call TI	Call TI
LM311PWR	ACTIVE	TSSOP	PW	8	2000	Green (RoHS & no Sb/Br)	CU NIPDAU	Level-1-260C-UNLIM
LM311PWRE4	ACTIVE	TSSOP	PW	8	2000	Green (RoHS & no Sb/Br)	CU NIPDAU	Level-1-260C-UNLIM
LM311Y	OBSOLETE	XCEPT	Y	0		TBD	Call TI	Call TI

⁽¹⁾ The marketing status values are defined as follows:

ACTIVE: Product device recommended for new designs.

LIFEBUY: TI has announced that the device will be discontinued, and a lifetime-buy period is in effect.

NRND: Not recommended for new designs. Device is in production to support existing customers, but TI does not recommend using this part in a new design.

PREVIEW: Device has been announced but is not in production. Samples may or may not be available.

OBSOLETE: TI has discontinued the production of the device.

⁽²⁾ Eco Plan - The planned eco-friendly classification: Pb-Free (RoHS), Pb-Free (RoHS Exempt), or Green (RoHS & no Sb/Br) - please check <http://www.ti.com/productcontent> for the latest availability information and additional product content details.

TBD: The Pb-Free/Green conversion plan has not been defined.

Pb-Free (RoHS): TI's terms "Lead-Free" or "Pb-Free" mean semiconductor products that are compatible with the current RoHS requirements for all 6 substances, including the requirement that lead not exceed 0.1% by weight in homogeneous materials. Where designed to be soldered at high temperatures, TI Pb-Free products are suitable for use in specified lead-free processes.

Pb-Free (RoHS Exempt): This component has a RoHS exemption for either 1) lead-based flip-chip solder bumps used between the die and package, or 2) lead-based die adhesive used between the die and leadframe. The component is otherwise considered Pb-Free (RoHS compatible) as defined above.

Green (RoHS & no Sb/Br): TI defines "Green" to mean Pb-Free (RoHS compatible), and free of Bromine (Br) and Antimony (Sb) based flame retardants (Br or Sb do not exceed 0.1% by weight in homogeneous material)

⁽³⁾ MSL, Peak Temp. -- The Moisture Sensitivity Level rating according to the JEDEC industry standard classifications, and peak solder temperature.

Important Information and Disclaimer:The information provided on this page represents TI's knowledge and belief as of the date that it is provided. TI bases its knowledge and belief on information provided by third parties, and makes no representation or warranty as to the accuracy of such information. Efforts are underway to better integrate information from third parties. TI has taken and continues to take reasonable steps to provide representative and accurate information but may not have conducted destructive testing or chemical analysis on incoming materials and chemicals. TI and TI suppliers consider certain information to be proprietary, and thus CAS numbers and other limited information may not be available for release.

In no event shall TI's liability arising out of such information exceed the total purchase price of the TI part(s) at issue in this document sold by TI to Customer on an annual basis.

JG (R-GDIP-T8)

CERAMIC DUAL-IN-LINE



- NOTES: A. All linear dimensions are in inches (millimeters).
 B. This drawing is subject to change without notice.
 C. This package can be hermetically sealed with a ceramic lid using glass frit.
 D. Index point is provided on cap for terminal identification.
 E. Falls within MIL STD 1835 GDIP1-T8

FK (S-CQCC-N**)

LEADLESS CERAMIC CHIP CARRIER

28 TERMINAL SHOWN



4040140/D 10/96

- NOTES:
- A. All linear dimensions are in inches (millimeters).
 - B. This drawing is subject to change without notice.
 - C. This package can be hermetically sealed with a metal lid.
 - D. The terminals are gold plated.
 - E. Falls within JEDEC MS-004

P (R-PDIP-T8)

PLASTIC DUAL-IN-LINE



- NOTES: A. All linear dimensions are in inches (millimeters).
 B. This drawing is subject to change without notice.
 C. Falls within JEDEC MS-001

For the latest package information, go to http://www.ti.com/sc/docs/package/pkg_info.htm

D (R-PDSO-G8)

PLASTIC SMALL-OUTLINE PACKAGE

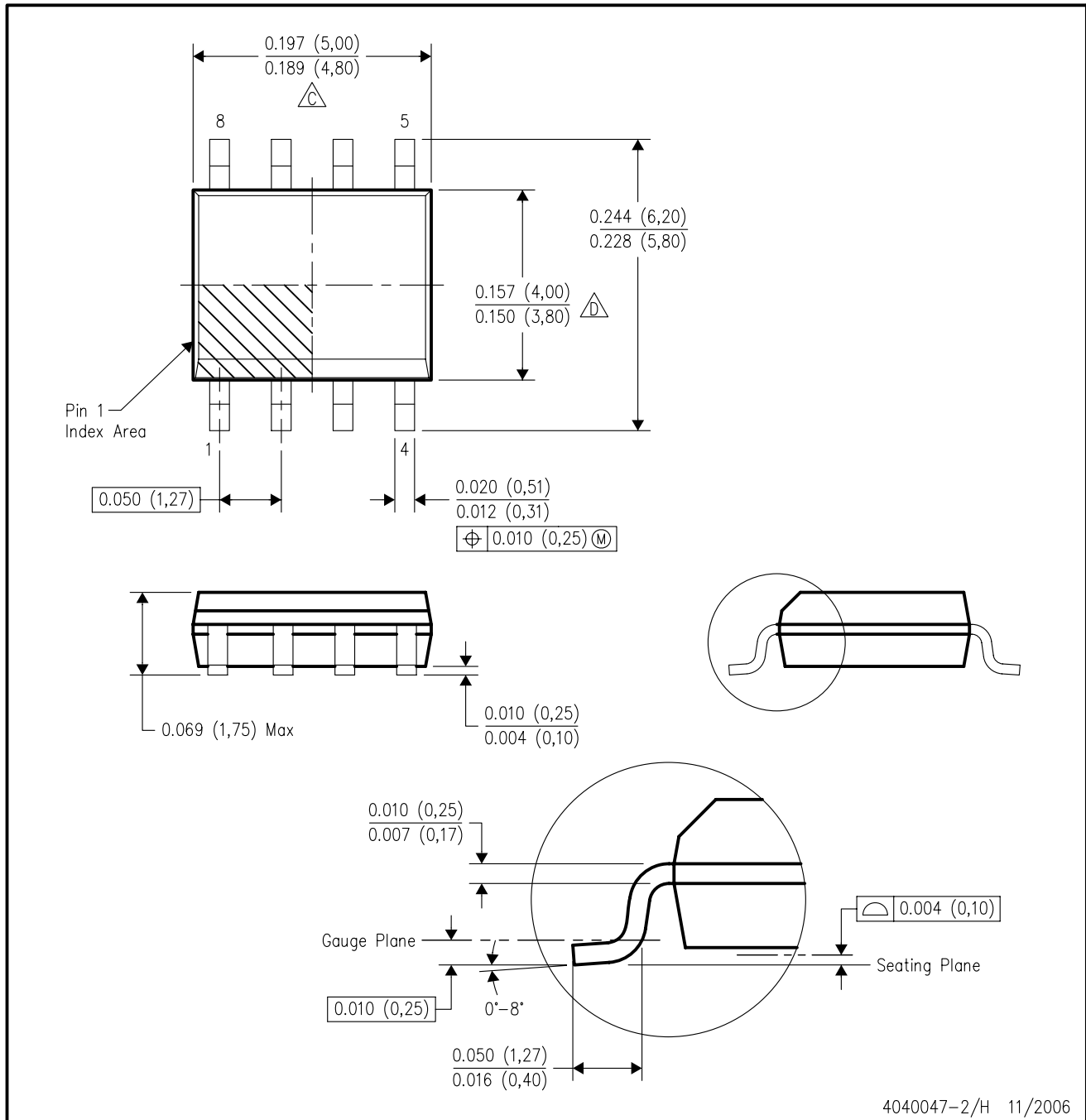

- NOTES:
- A. All linear dimensions are in inches (millimeters).
 - B. This drawing is subject to change without notice.
 - $\triangle C$ Body length does not include mold flash, protrusions, or gate burrs. Mold flash, protrusions, or gate burrs shall not exceed .006 (0,15) per end.
 - $\triangle D$ Body width does not include interlead flash. Interlead flash shall not exceed .017 (0,43) per side.
 - E. Reference JEDEC MS-012 variation AA.

MECHANICAL DATA

PS (R-PDSO-G8)

PLASTIC SMALL-OUTLINE PACKAGE

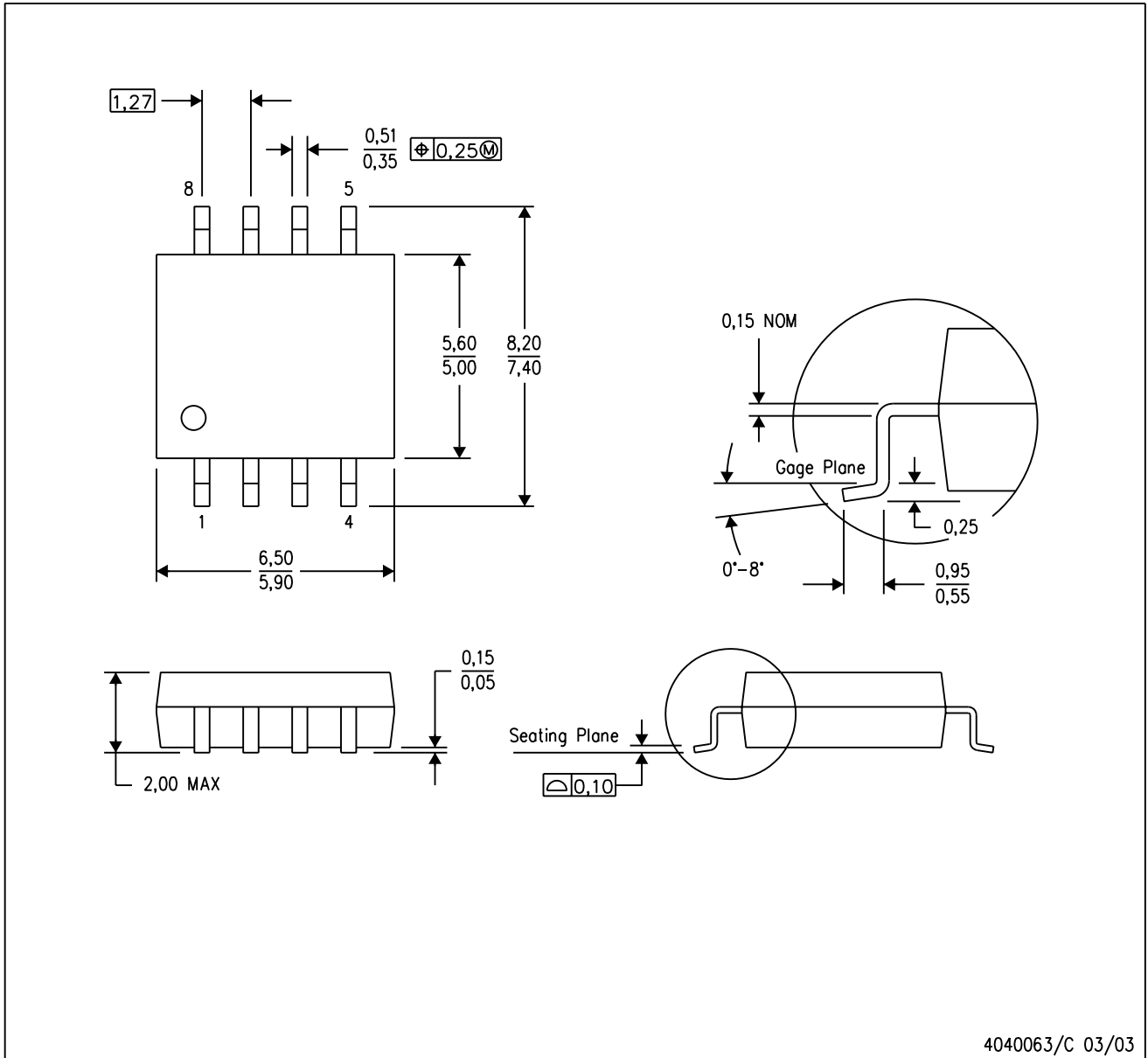

- NOTES:
- A. All linear dimensions are in millimeters.
 - B. This drawing is subject to change without notice.
 - C. Body dimensions do not include mold flash or protrusion, not to exceed 0,15.

PW (R-PDSO-G**)

PLASTIC SMALL-OUTLINE PACKAGE

14 PINS SHOWN



4040064/F 01/97

- NOTES: A. All linear dimensions are in millimeters.
 B. This drawing is subject to change without notice.
 C. Body dimensions do not include mold flash or protrusion not to exceed 0,15.
 D. Falls within JEDEC MO-153

IMPORTANT NOTICE

Texas Instruments Incorporated and its subsidiaries (TI) reserve the right to make corrections, modifications, enhancements, improvements, and other changes to its products and services at any time and to discontinue any product or service without notice. Customers should obtain the latest relevant information before placing orders and should verify that such information is current and complete. All products are sold subject to TI's terms and conditions of sale supplied at the time of order acknowledgment.

TI warrants performance of its hardware products to the specifications applicable at the time of sale in accordance with TI's standard warranty. Testing and other quality control techniques are used to the extent TI deems necessary to support this warranty. Except where mandated by government requirements, testing of all parameters of each product is not necessarily performed.

TI assumes no liability for applications assistance or customer product design. Customers are responsible for their products and applications using TI components. To minimize the risks associated with customer products and applications, customers should provide adequate design and operating safeguards.

TI does not warrant or represent that any license, either express or implied, is granted under any TI patent right, copyright, mask work right, or other TI intellectual property right relating to any combination, machine, or process in which TI products or services are used. Information published by TI regarding third-party products or services does not constitute a license from TI to use such products or services or a warranty or endorsement thereof. Use of such information may require a license from a third party under the patents or other intellectual property of the third party, or a license from TI under the patents or other intellectual property of TI.

Reproduction of information in TI data books or data sheets is permissible only if reproduction is without alteration and is accompanied by all associated warranties, conditions, limitations, and notices. Reproduction of this information with alteration is an unfair and deceptive business practice. TI is not responsible or liable for such altered documentation.

Resale of TI products or services with statements different from or beyond the parameters stated by TI for that product or service voids all express and any implied warranties for the associated TI product or service and is an unfair and deceptive business practice. TI is not responsible or liable for any such statements.

Following are URLs where you can obtain information on other Texas Instruments products and application solutions:

Products		Applications	
Amplifiers	amplifier.ti.com	Audio	www.ti.com/audio
Data Converters	dataconverter.ti.com	Automotive	www.ti.com/automotive
DSP	dsp.ti.com	Broadband	www.ti.com/broadband
Interface	interface.ti.com	Digital Control	www.ti.com/digitalcontrol
Logic	logic.ti.com	Military	www.ti.com/military
Power Mgmt	power.ti.com	Optical Networking	www.ti.com/opticalnetwork
Microcontrollers	microcontroller.ti.com	Security	www.ti.com/security
Low Power Wireless	www.ti.com/lpw	Telephony	www.ti.com/telephony
		Video & Imaging	www.ti.com/video
		Wireless	www.ti.com/wireless

Mailing Address: Texas Instruments
Post Office Box 655303 Dallas, Texas 75265