

TL594 PULSE-WIDTH-MODULATION CONTROL CIRCUIT

SLVS052F – APRIL 1988 – REVISED NOVEMBER 2003

- Complete PWM Power-Control Circuitry
- Uncommitted Outputs for 200-mA Sink or Source Current
- Output Control Selects Single-Ended or Push-Pull Operation
- Internal Circuitry Prohibits Double Pulse at Either Output
- Variable Dead Time Provides Control Over Total Range
- Internal Regulator Provides a Stable 5-V Reference Supply Trimmed to 1%
- Circuit Architecture Allows Easy Synchronization
- Undervoltage Lockout for Low- V_{CC} Conditions

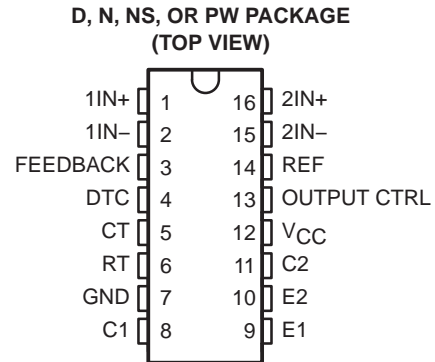

description/ordering information

The TL594 incorporates all the functions required in the construction of a pulse-width-modulation (PWM) control circuit on a single chip. Designed primarily for power-supply control, this device offers the systems engineer the flexibility to tailor the power-supply control circuitry to a specific application.

The TL594 contains two error amplifiers, an on-chip adjustable oscillator, a dead-time control (DTC) comparator, a pulse-steering control flip-flop, a 5-V regulator with a precision of 1%, an undervoltage lockout control circuit, and output control circuitry.

The error amplifiers have a common-mode voltage range of -0.3 V to $V_{CC} - 2\text{ V}$. The DTC comparator has a fixed offset that provides approximately 5% dead time. The on-chip oscillator can be bypassed by terminating RT to the reference output and providing a sawtooth input to CT, or it can be used to drive the common circuitry in synchronous multiple-rail power supplies.

The uncommitted output transistors provide either common-emitter or emitter-follower output capability. Each device provides for push-pull or single-ended output operation, with selection by means of the output-control function. The architecture of these devices prohibits the possibility of either output being pulsed twice during push-pull operation. The undervoltage lockout control circuit locks the outputs off until the internal circuitry is operational.

The TL594C is characterized for operation from 0°C to 70°C . The TL594I is characterized for operation from -40°C to 85°C .



Please be aware that an important notice concerning availability, standard warranty, and use in critical applications of Texas Instruments semiconductor products and disclaimers thereto appears at the end of this data sheet.

PRODUCTION DATA information is current as of publication date. Products conform to specifications per the terms of Texas Instruments standard warranty. Production processing does not necessarily include testing of all parameters.

 **TEXAS
INSTRUMENTS**

POST OFFICE BOX 655303 • DALLAS, TEXAS 75265

Copyright © 2003, Texas Instruments Incorporated

TL594

PULSE-WIDTH-MODULATION CONTROL CIRCUIT

SLVS052F – APRIL 1988 – REVISED NOVEMBER 2003

description/ordering information (continued)

ORDERING INFORMATION

TA	PACKAGE†		ORDERABLE PART NUMBER	TOP-SIDE MARKING
0°C to 70°C	PDIP (N)	Tube of 25	TL594CN	TL594CN
	SOIC (D)	Tube of 40	TL594CD	TL594C
		Reel of 2500	TL594CDR	
	SOP (NS)	Reel of 2000	TL594CNSR	TL594
	TSSOP (PW)	Tube of 90	TL594CPW	T594
		Reel of 2000	TL594CPWR	
–40°C to 85°C	PDIP (N)	Tube of 25	TL594IN	TL594IN
	SOIC (D)	Tube of 40	TL594ID	TL594I
		Reel of 2500	TL594IDR	
	SOP (NS)	Reel of 2000	TL594INSR	TL594I
	TSSOP (PW)	Tube of 90	TL594IPW	Z594
		Reel of 2000	TL594IPWR	

† Package drawings, standard packing quantities, thermal data, symbolization, and PCB design guidelines are available at www.ti.com/sc/package.

FUNCTION TABLE

INPUT	OUTPUT FUNCTION
OUTPUT CTRL	
$V_I = 0$	Single-ended or parallel output
$V_I = V_{ref}$	Normal push-pull operation

functional block diagram

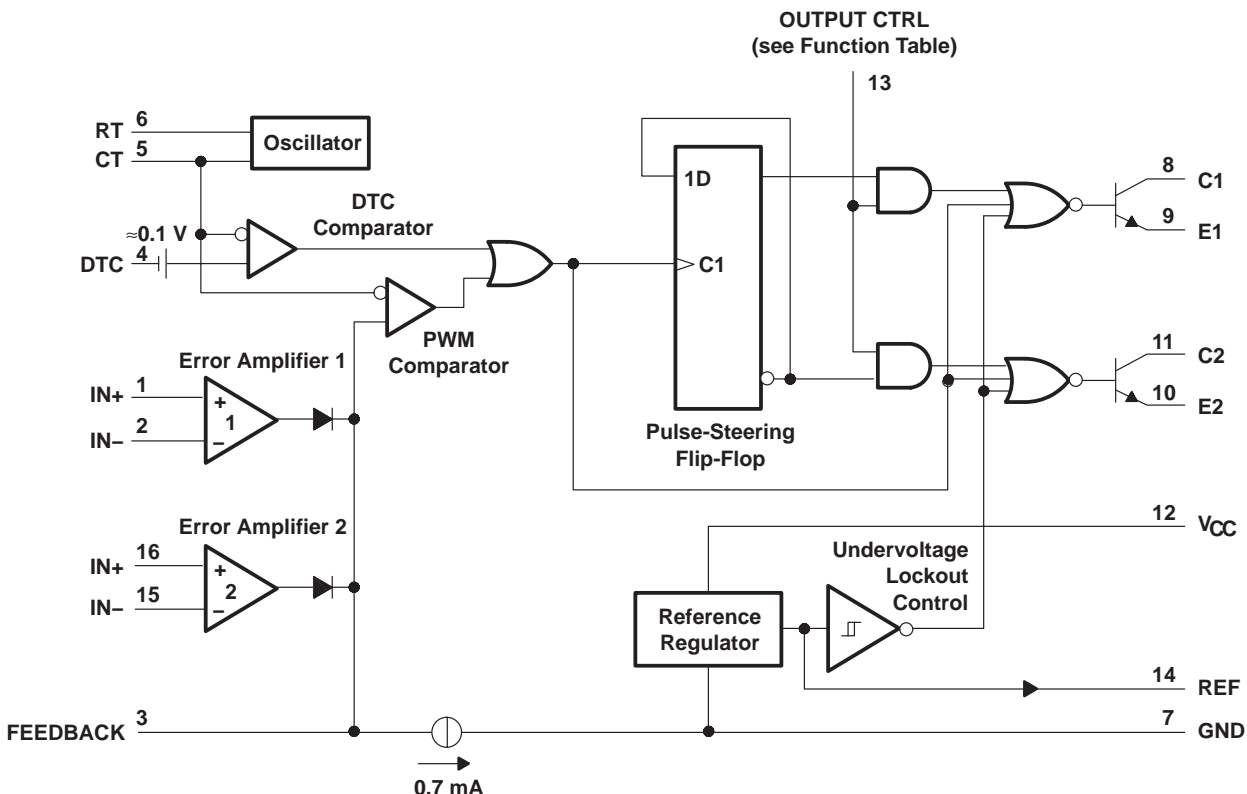

absolute maximum ratings over operating free-air temperature range (unless otherwise noted)†

Supply voltage, V_{CC} (see Note 1)	41 V
Amplifier input voltage	$V_{CC} + 0.3$ V
Collector output voltage	41 V
Collector output current	250 mA
Package thermal impedance, θ_{JA} (see Notes 2 and 3):	
D package	73°C/W
N package	67°C/W
NS package	64°C/W
PW package	108°C/W
Operating virtual junction temperature, T_J	150°C
Storage temperature range, T_{Stg}	-65°C to 150°C

† Stresses beyond those listed under "absolute maximum ratings" may cause permanent damage to the device. These are stress ratings only, and functional operation of the device at these or any other conditions beyond those indicated under "recommended operating conditions" is not implied. Exposure to absolute-maximum-rated conditions for extended periods may affect device reliability.

- NOTES:
1. All voltage values, except differential voltages, are with respect to the network ground terminal.
 2. Maximum power dissipation is a function of $T_J(\max)$, θ_{JA} , and T_A . The maximum allowable power dissipation at any allowable ambient temperature is $P_D = (T_J(\max) - T_A)/\theta_{JA}$. Operating at the absolute maximum T_J of 150°C can affect reliability.
 3. The package thermal impedance is calculated in accordance with JESD 51-7.

TL594

PULSE-WIDTH-MODULATION CONTROL CIRCUIT

SLVS052F – APRIL 1988 – REVISED NOVEMBER 2003

recommended operating conditions

		MIN	MAX	UNIT	
V_{CC}	Supply voltage	7	40	V	
V_I	Amplifier input voltage	-0.3	$V_{CC}-2$	V	
V_O	Collector output voltage		40	V	
	Collector output current (each transistor)		200	mA	
	Current into feedback terminal		0.3	mA	
C_T	Timing capacitor	0.47	10000	nF	
R_T	Timing resistor	1.8	500	k Ω	
f_{osc}	Oscillator frequency	1	300	kHz	
T_A	Operating free-air temperature	TL594C	0	70	$^{\circ}$ C
		TL594I	-40	85	$^{\circ}$ C

TL594 PULSE-WIDTH-MODULATION CONTROL CIRCUIT

SLVS052F – APRIL 1988 – REVISED NOVEMBER 2003

**electrical characteristics over recommended operating conditions, $V_{CC} = 15\text{ V}$,
(unless otherwise noted)**

reference section

PARAMETER	TEST CONDITIONS†	TL594C, TL594I			UNIT
		MIN	TYP‡	MAX	
Output voltage (REF)	$I_O = 1\text{ mA}$, $T_A = 25^\circ\text{C}$	4.95	5	5.05	V
Input regulation	$V_{CC} = 7\text{ V to }40\text{ V}$, $T_A = 25^\circ\text{C}$		2	25	mV
Output regulation	$I_O = 1\text{ to }10\text{ mA}$, $T_A = 25^\circ\text{C}$		14	35	mV
Output-voltage change with temperature	$\Delta T_A = \text{MIN to MAX}$		2	10	mV/V
Short-circuit output current§	$V_{ref} = 0$	10	35	50	mA

† For conditions shown as MIN or MAX, use the appropriate value specified under recommended operating conditions.

‡ All typical values, except for parameter changes with temperature, are at $T_A = 25^\circ\text{C}$.

§ Duration of the short circuit should not exceed one second.

amplifier section (see Figure 1)

PARAMETER	TEST CONDITIONS	TL594C, TL594I			UNIT
		MIN	TYP‡	MAX	
Input offset voltage, error amplifier	FEEDBACK = 2.5 V		2	10	mV
Input offset current	FEEDBACK = 2.5 V		25	250	nA
Input bias current	FEEDBACK = 2.5 V		0.2	1	μA
Common-mode input voltage range, error amplifier	$V_{CC} = 7\text{ V to }40\text{ V}$		0.3 to $V_{CC}-2$		V
Open-loop voltage amplification, error amplifier	$\Delta V_O = 3\text{ V}$, $R_L = 2\text{ k}\Omega$, $V_O = 0.5\text{ V to }3.5\text{ V}$	70	95		dB
Unity-gain bandwidth	$V_O = 0.5\text{ V to }3.5\text{ V}$, $R_L = 2\text{ k}\Omega$		800		kHz
Common-mode rejection ratio, error amplifier	$V_{CC} = 40\text{ V}$, $T_A = 25^\circ\text{C}$	65	80		dB
Output sink current, FEEDBACK	$V_{ID} = -15\text{ mV to }-5\text{ V}$, FEEDBACK = 0.5 V	0.3	0.7		mA
Output source current, FEEDBACK	$V_{ID} = 15\text{ mV to }5\text{ V}$, FEEDBACK = 3.5 V	-2			mA

‡ All typical values, except for parameter changes with temperature, are at $T_A = 25^\circ\text{C}$.

oscillator section, $C_T = 0.01\ \mu\text{F}$, $R_T = 12\text{ k}\Omega$ (see Figure 2)

PARAMETER	TEST CONDITIONS†	TL594C, TL594I			UNIT
		MIN	TYP‡	MAX	
Frequency			10		kHz
Standard deviation of frequency¶	All values of V_{CC} , C_T , R_T , and T_A constant		100		Hz/kHz
Frequency change with voltage	$V_{CC} = 7\text{ V to }40\text{ V}$, $T_A = 25^\circ\text{C}$		1		Hz/kHz
Frequency change with temperature#	$\Delta T_A = \text{MIN to MAX}$			50	Hz/kHz

† For conditions shown as MIN or MAX, use the appropriate value specified under recommended operating conditions.

‡ All typical values, except for parameter changes with temperature, are at $T_A = 25^\circ\text{C}$.

¶ Standard deviation is a measure of the statistical distribution about the mean, as derived from the formula:

$$\sigma = \sqrt{\frac{\sum_{n=1}^N (x_n - \bar{x})^2}{N - 1}}$$

Temperature coefficient of timing capacitor and timing resistor is not taken into account.



TL594

PULSE-WIDTH-MODULATION CONTROL CIRCUIT

SLVS052F – APRIL 1988 – REVISED NOVEMBER 2003

electrical characteristics over recommended operating free-air temperature range, $V_{CC} = 15\text{ V}$, (unless otherwise noted) (continued)

dead-time control section (see Figure 2)

PARAMETER	TEST CONDITIONS	TL594C, TL594I		UNIT	
		MIN	TYP†		MAX
Input bias current	$V_I = 0$ to 5.25 V		-2	-10	μA
Maximum duty cycle, each output	DTC = 0 V	0.45			
Input threshold voltage	Zero duty cycle		3	3.3	V
	Maximum duty cycle	0			

† All typical values, except for parameter changes with temperature, are at $T_A = 25^\circ\text{C}$.

output section

PARAMETER	TEST CONDITIONS	TL594C, TL594I		UNIT	
		MIN	TYP†		MAX
Collector off-state current	$V_C = 40\text{ V}$, $V_E = 0\text{ V}$, $V_{CC} = 40\text{ V}$		2	100	μA
	DTC and OUTPUT CTRL = 0 V , $V_C = 15\text{ V}$, $V_E = 0\text{ V}$, $V_{CC} = 1$ to 3 V		4	200	
Emitter off-state current	$V_{CC} = V_C = 40\text{ V}$, $V_E = 0$			-100	μA
Collector-emitter saturation voltage	Common emitter $V_E = 0$, $I_C = 200\text{ mA}$		1.1	1.3	V
	Emitter follower $V_C = 15\text{ V}$, $I_E = -200\text{ mA}$		1.5	2.5	
Output control input current	$V_I = V_{ref}$			3.5	mA

† All typical values, except for parameter changes with temperature, are at $T_A = 25^\circ\text{C}$.

pwm comparator section (see Figure 2)

PARAMETER	TEST CONDITIONS	TL594C, TL594I		UNIT	
		MIN	TYP†		MAX
Input threshold voltage, FEEDBACK	Zero duty cycle		4	4.5	V
Input sink current, FEEDBACK	FEEDBACK = 0.5 V	0.3	0.7		mA

† All typical values, except for parameter changes with temperature, are at $T_A = 25^\circ\text{C}$.

undervoltage lockout section (see Figure 2)

PARAMETER	TEST CONDITIONS‡	TL594C, TL594I		UNIT	
		MIN	MAX		
Threshold voltage	$T_A = 25^\circ\text{C}$			6	V
	$\Delta T_A = \text{MIN to MAX}$	3.5	6.9		
Hysteresis§		100		mV	

‡ For conditions shown as MIN or MAX, use the appropriate value specified under recommended operating conditions.

§ Hysteresis is the difference between the positive-going input threshold voltage and the negative-going input threshold voltage.

PARAMETER	TEST CONDITIONS	TL594C, TL594I		UNIT	
		MIN	TYP†		MAX
Standby supply current	RT at V_{ref} , All other inputs and outputs open	$V_{CC} = 15\text{ V}$	9	15	mA
		$V_{CC} = 40\text{ V}$	11	18	
Average supply current	DTC = 2 V , See Figure 2	12.4		mA	

† All typical values, except for parameter changes with temperature, are at $T_A = 25^\circ\text{C}$.



electrical characteristics over recommended operating free-air temperature range, $V_{CC} = 15\text{ V}$, (unless otherwise noted) (continued)

switching characteristics, $T_A = 25^\circ\text{C}$

PARAMETER	TEST CONDITIONS	TL594C, TL594I			UNIT
		MIN	TYP†	MAX	
Output-voltage rise time	Common-emitter configuration (see Figure 3)		100	200	ns
Output-voltage fall time			30	100	ns
Output-voltage rise time	Emitter-follower configuration (see Figure 4)		200	400	ns
Output-voltage fall time			45	100	ns

† All typical values, except for parameter changes with temperature, are at $T_A = 25^\circ\text{C}$.

PARAMETER MEASUREMENT INFORMATION

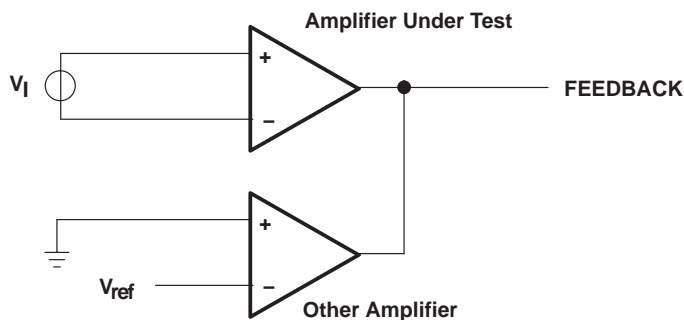

Figure 1. Amplifier-Characteristics Test Circuit

TL594 PULSE-WIDTH-MODULATION CONTROL CIRCUIT

SLVS052F – APRIL 1988 – REVISED NOVEMBER 2003

PARAMETER MEASUREMENT INFORMATION

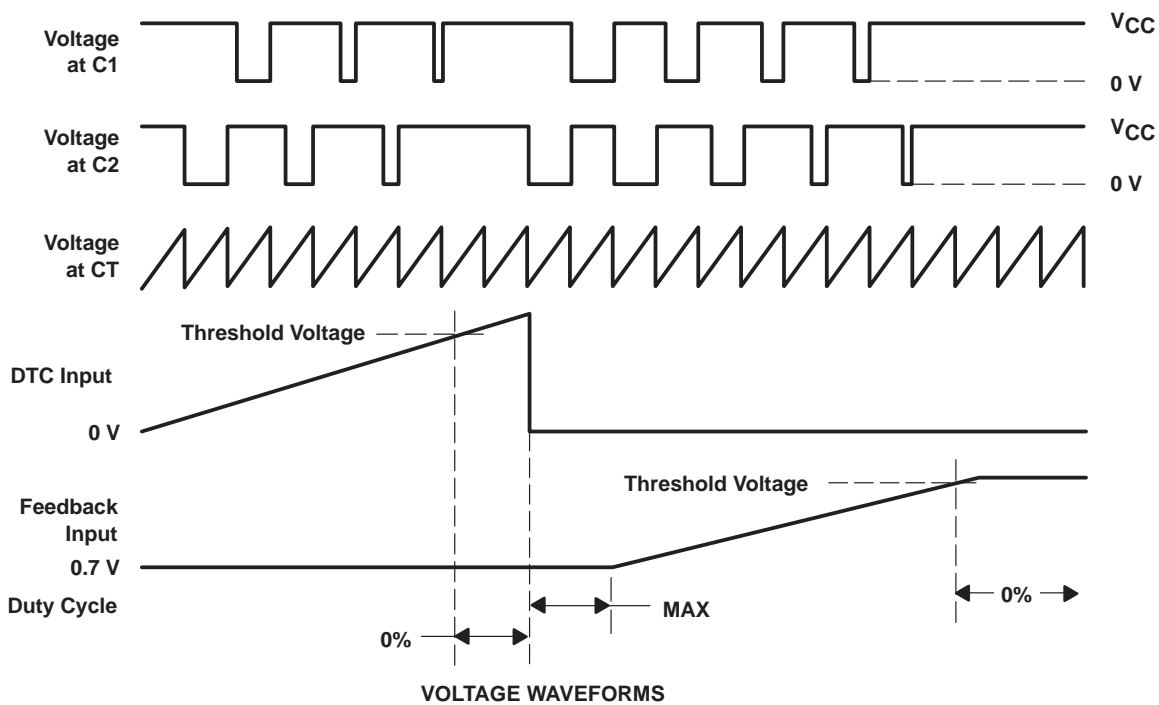
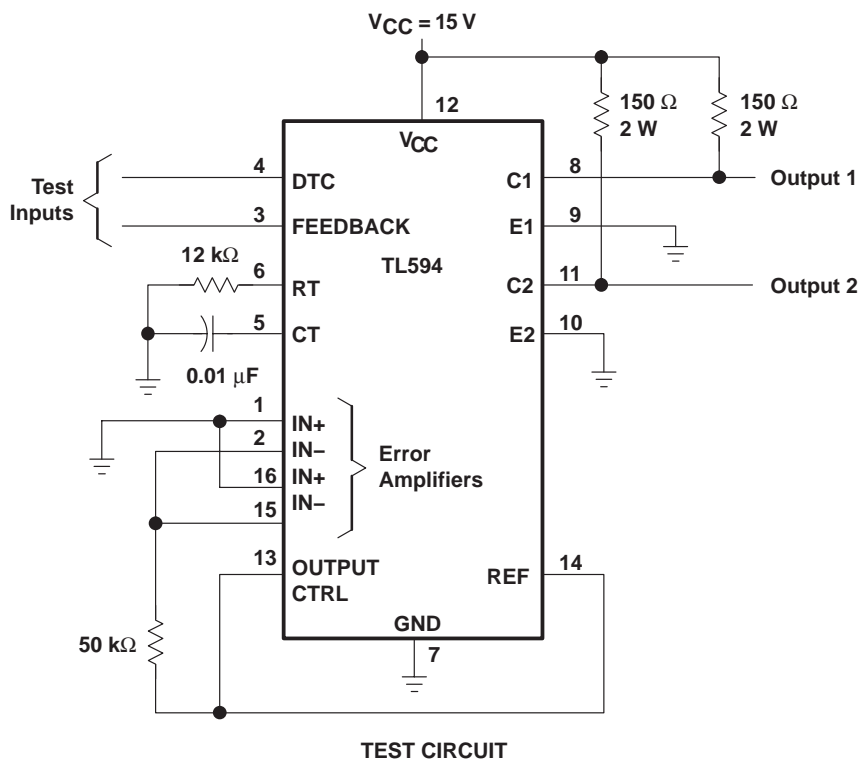

Figure 2. Operational Test Circuit and Waveforms

PARAMETER MEASUREMENT INFORMATION

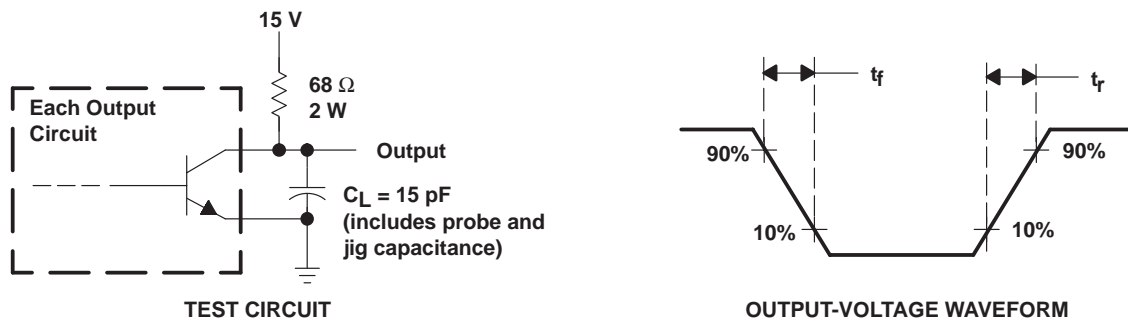

Figure 3. Common-Emitter Configuration

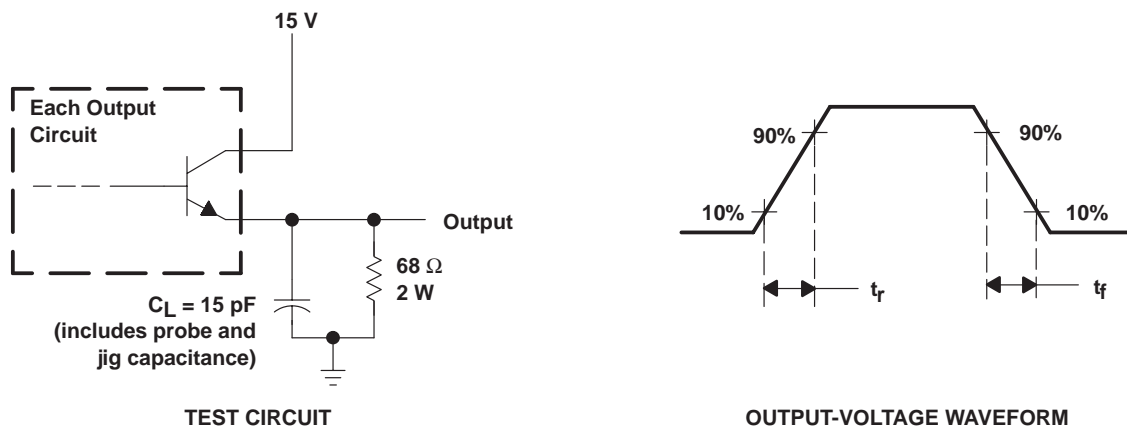

Figure 4. Emitter-Follower Configuration

TL594 PULSE-WIDTH-MODULATION CONTROL CIRCUIT

SLVS052F – APRIL 1988 – REVISED NOVEMBER 2003

TYPICAL CHARACTERISTICS

OSCILLATOR FREQUENCY AND FREQUENCY VARIATION[†]

vs
TIMING RESISTANCE

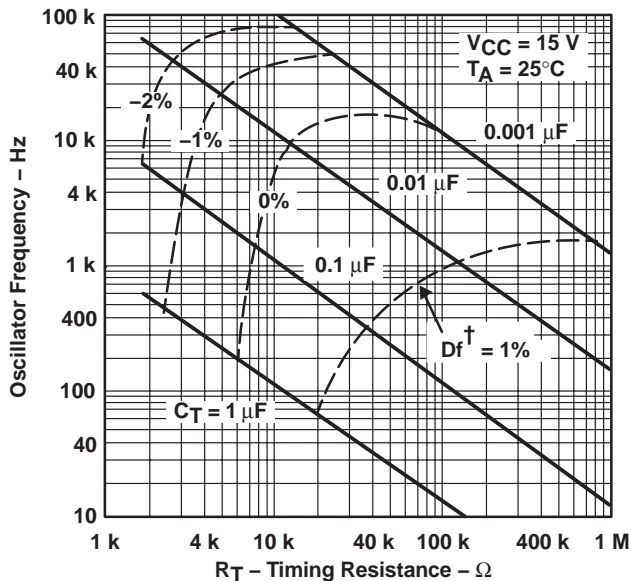

[†] Frequency variation (Δf) is the change in oscillator frequency that occurs over the full temperature range.

Figure 5

AMPLIFIER VOLTAGE AMPLIFICATION vs FREQUENCY

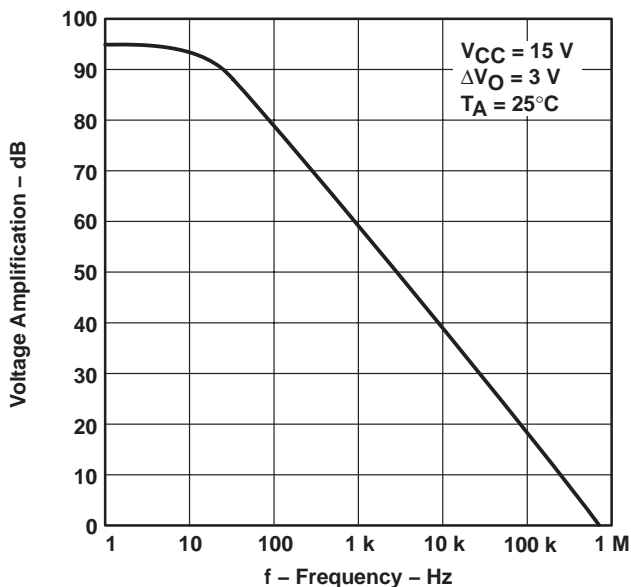

Figure 6



PACKAGING INFORMATION

Orderable Device	Status ⁽¹⁾	Package Type	Package Drawing	Pins	Package Qty	Eco Plan ⁽²⁾	Lead/Ball Finish	MSL Peak Temp ⁽³⁾
TL594CD	ACTIVE	SOIC	D	16	40	Green (RoHS & no Sb/Br)	CU NIPDAU	Level-1-260C-UNLIM
TL594CDE4	ACTIVE	SOIC	D	16	40	Green (RoHS & no Sb/Br)	CU NIPDAU	Level-1-260C-UNLIM
TL594CDR	ACTIVE	SOIC	D	16	2500	Green (RoHS & no Sb/Br)	CU NIPDAU	Level-1-260C-UNLIM
TL594CDRE4	ACTIVE	SOIC	D	16	2500	Green (RoHS & no Sb/Br)	CU NIPDAU	Level-1-260C-UNLIM
TL594CN	ACTIVE	PDIP	N	16	25	Pb-Free (RoHS)	CU NIPDAU	N / A for Pkg Type
TL594CNE4	ACTIVE	PDIP	N	16	25	Pb-Free (RoHS)	CU NIPDAU	N / A for Pkg Type
TL594CNSR	ACTIVE	SO	NS	16	2000	Green (RoHS & no Sb/Br)	CU NIPDAU	Level-1-260C-UNLIM
TL594CNSRE4	ACTIVE	SO	NS	16	2000	Green (RoHS & no Sb/Br)	CU NIPDAU	Level-1-260C-UNLIM
TL594CPW	ACTIVE	TSSOP	PW	16	90	Green (RoHS & no Sb/Br)	CU NIPDAU	Level-1-260C-UNLIM
TL594CPWE4	ACTIVE	TSSOP	PW	16	90	Green (RoHS & no Sb/Br)	CU NIPDAU	Level-1-260C-UNLIM
TL594CPWG4	ACTIVE	TSSOP	PW	16	90	Green (RoHS & no Sb/Br)	CU NIPDAU	Level-1-260C-UNLIM
TL594CPWR	ACTIVE	TSSOP	PW	16	2000	Green (RoHS & no Sb/Br)	CU NIPDAU	Level-1-260C-UNLIM
TL594CPWRE4	ACTIVE	TSSOP	PW	16	2000	Green (RoHS & no Sb/Br)	CU NIPDAU	Level-1-260C-UNLIM
TL594CPWRG4	ACTIVE	TSSOP	PW	16	2000	Green (RoHS & no Sb/Br)	CU NIPDAU	Level-1-260C-UNLIM
TL594ID	ACTIVE	SOIC	D	16	40	Green (RoHS & no Sb/Br)	CU NIPDAU	Level-1-260C-UNLIM
TL594IDE4	ACTIVE	SOIC	D	16	40	Green (RoHS & no Sb/Br)	CU NIPDAU	Level-1-260C-UNLIM
TL594IDR	ACTIVE	SOIC	D	16	2500	Green (RoHS & no Sb/Br)	CU NIPDAU	Level-1-260C-UNLIM
TL594IDRE4	ACTIVE	SOIC	D	16	2500	Green (RoHS & no Sb/Br)	CU NIPDAU	Level-1-260C-UNLIM
TL594IN	ACTIVE	PDIP	N	16	25	Pb-Free (RoHS)	CU NIPDAU	N / A for Pkg Type
TL594INE4	ACTIVE	PDIP	N	16	25	Pb-Free (RoHS)	CU NIPDAU	N / A for Pkg Type
TL594INSR	ACTIVE	SO	NS	16	2000	Green (RoHS & no Sb/Br)	CU NIPDAU	Level-1-260C-UNLIM
TL594INSRG4	ACTIVE	SO	NS	16	2000	Green (RoHS & no Sb/Br)	CU NIPDAU	Level-1-260C-UNLIM
TL594IPW	ACTIVE	TSSOP	PW	16	90	Green (RoHS & no Sb/Br)	CU NIPDAU	Level-1-260C-UNLIM
TL594IPWE4	ACTIVE	TSSOP	PW	16	90	Green (RoHS & no Sb/Br)	CU NIPDAU	Level-1-260C-UNLIM
TL594IPWG4	ACTIVE	TSSOP	PW	16	90	Green (RoHS & no Sb/Br)	CU NIPDAU	Level-1-260C-UNLIM

Orderable Device	Status ⁽¹⁾	Package Type	Package Drawing	Pins	Package Qty	Eco Plan ⁽²⁾	Lead/Ball Finish	MSL Peak Temp ⁽³⁾
TL594IPWR	ACTIVE	TSSOP	PW	16	2000	Green (RoHS & no Sb/Br)	CU NIPDAU	Level-1-260C-UNLIM
TL594IPWRE4	ACTIVE	TSSOP	PW	16	2000	Green (RoHS & no Sb/Br)	CU NIPDAU	Level-1-260C-UNLIM
TL594IPWRG4	ACTIVE	TSSOP	PW	16	2000	Green (RoHS & no Sb/Br)	CU NIPDAU	Level-1-260C-UNLIM

⁽¹⁾ The marketing status values are defined as follows:

ACTIVE: Product device recommended for new designs.

LIFEBUY: TI has announced that the device will be discontinued, and a lifetime-buy period is in effect.

NRND: Not recommended for new designs. Device is in production to support existing customers, but TI does not recommend using this part in a new design.

PREVIEW: Device has been announced but is not in production. Samples may or may not be available.

OBSOLETE: TI has discontinued the production of the device.

⁽²⁾ Eco Plan - The planned eco-friendly classification: Pb-Free (RoHS), Pb-Free (RoHS Exempt), or Green (RoHS & no Sb/Br) - please check <http://www.ti.com/productcontent> for the latest availability information and additional product content details.

TBD: The Pb-Free/Green conversion plan has not been defined.

Pb-Free (RoHS): TI's terms "Lead-Free" or "Pb-Free" mean semiconductor products that are compatible with the current RoHS requirements for all 6 substances, including the requirement that lead not exceed 0.1% by weight in homogeneous materials. Where designed to be soldered at high temperatures, TI Pb-Free products are suitable for use in specified lead-free processes.

Pb-Free (RoHS Exempt): This component has a RoHS exemption for either 1) lead-based flip-chip solder bumps used between the die and package, or 2) lead-based die adhesive used between the die and leadframe. The component is otherwise considered Pb-Free (RoHS compatible) as defined above.

Green (RoHS & no Sb/Br): TI defines "Green" to mean Pb-Free (RoHS compatible), and free of Bromine (Br) and Antimony (Sb) based flame retardants (Br or Sb do not exceed 0.1% by weight in homogeneous material)

⁽³⁾ MSL, Peak Temp. -- The Moisture Sensitivity Level rating according to the JEDEC industry standard classifications, and peak solder temperature.

Important Information and Disclaimer:The information provided on this page represents TI's knowledge and belief as of the date that it is provided. TI bases its knowledge and belief on information provided by third parties, and makes no representation or warranty as to the accuracy of such information. Efforts are underway to better integrate information from third parties. TI has taken and continues to take reasonable steps to provide representative and accurate information but may not have conducted destructive testing or chemical analysis on incoming materials and chemicals. TI and TI suppliers consider certain information to be proprietary, and thus CAS numbers and other limited information may not be available for release.

In no event shall TI's liability arising out of such information exceed the total purchase price of the TI part(s) at issue in this document sold by TI to Customer on an annual basis.

N (R-PDIP-T**)

PLASTIC DUAL-IN-LINE PACKAGE

16 PINS SHOWN



- NOTES:
- A. All linear dimensions are in inches (millimeters).
 - B. This drawing is subject to change without notice.
 - C Falls within JEDEC MS-001, except 18 and 20 pin minimum body length (Dim A).
 - D The 20 pin end lead shoulder width is a vendor option, either half or full width.

4040049/E 12/2002

D (R-PDSO-G16)

PLASTIC SMALL-OUTLINE PACKAGE

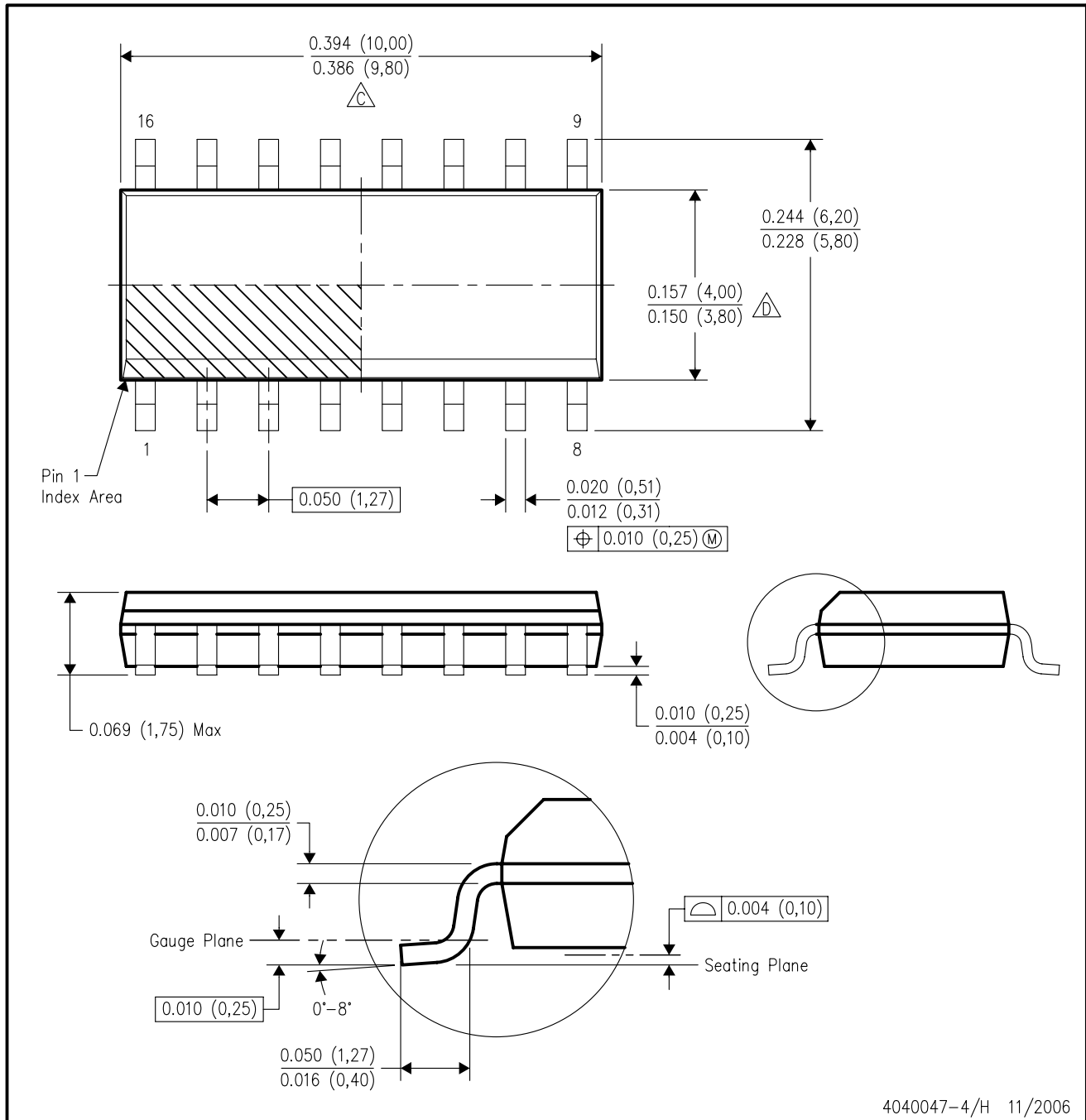

- NOTES:
- A. All linear dimensions are in inches (millimeters).
 - B. This drawing is subject to change without notice.
 - C. Body length does not include mold flash, protrusions, or gate burrs. Mold flash, protrusions, or gate burrs shall not exceed .006 (0,15) per end.
 - D. Body width does not include interlead flash. Interlead flash shall not exceed .017 (0,43) per side.
 - E. Reference JEDEC MS-012 variation AC.

MECHANICAL DATA

NS (R-PDSO-G**)

PLASTIC SMALL-OUTLINE PACKAGE

14-PINS SHOWN



- NOTES:
- A. All linear dimensions are in millimeters.
 - B. This drawing is subject to change without notice.
 - C. Body dimensions do not include mold flash or protrusion, not to exceed 0,15.

PW (R-PDSO-G**)

PLASTIC SMALL-OUTLINE PACKAGE

14 PINS SHOWN



4040064/F 01/97

- NOTES: A. All linear dimensions are in millimeters.
 B. This drawing is subject to change without notice.
 C. Body dimensions do not include mold flash or protrusion not to exceed 0,15.
 D. Falls within JEDEC MO-153

IMPORTANT NOTICE

Texas Instruments Incorporated and its subsidiaries (TI) reserve the right to make corrections, modifications, enhancements, improvements, and other changes to its products and services at any time and to discontinue any product or service without notice. Customers should obtain the latest relevant information before placing orders and should verify that such information is current and complete. All products are sold subject to TI's terms and conditions of sale supplied at the time of order acknowledgment.

TI warrants performance of its hardware products to the specifications applicable at the time of sale in accordance with TI's standard warranty. Testing and other quality control techniques are used to the extent TI deems necessary to support this warranty. Except where mandated by government requirements, testing of all parameters of each product is not necessarily performed.

TI assumes no liability for applications assistance or customer product design. Customers are responsible for their products and applications using TI components. To minimize the risks associated with customer products and applications, customers should provide adequate design and operating safeguards.

TI does not warrant or represent that any license, either express or implied, is granted under any TI patent right, copyright, mask work right, or other TI intellectual property right relating to any combination, machine, or process in which TI products or services are used. Information published by TI regarding third-party products or services does not constitute a license from TI to use such products or services or a warranty or endorsement thereof. Use of such information may require a license from a third party under the patents or other intellectual property of the third party, or a license from TI under the patents or other intellectual property of TI.

Reproduction of information in TI data books or data sheets is permissible only if reproduction is without alteration and is accompanied by all associated warranties, conditions, limitations, and notices. Reproduction of this information with alteration is an unfair and deceptive business practice. TI is not responsible or liable for such altered documentation.

Resale of TI products or services with statements different from or beyond the parameters stated by TI for that product or service voids all express and any implied warranties for the associated TI product or service and is an unfair and deceptive business practice. TI is not responsible or liable for any such statements.

Following are URLs where you can obtain information on other Texas Instruments products and application solutions:

Products		Applications	
Amplifiers	amplifier.ti.com	Audio	www.ti.com/audio
Data Converters	dataconverter.ti.com	Automotive	www.ti.com/automotive
DSP	dsp.ti.com	Broadband	www.ti.com/broadband
Interface	interface.ti.com	Digital Control	www.ti.com/digitalcontrol
Logic	logic.ti.com	Military	www.ti.com/military
Power Mgmt	power.ti.com	Optical Networking	www.ti.com/opticalnetwork
Microcontrollers	microcontroller.ti.com	Security	www.ti.com/security
Low Power Wireless	www.ti.com/lpw	Telephony	www.ti.com/telephony
		Video & Imaging	www.ti.com/video
		Wireless	www.ti.com/wireless

Mailing Address: Texas Instruments
Post Office Box 655303 Dallas, Texas 75265